

Bloc 1

BLOC 1 / CAPTEURS ET MISE EN FORME**Mission 1 - Abaisser une tension**

Proposer un circuit permettant d'abaisser une tension d'un facteur k .

$$0 < k < 1$$

Mission 2 -  lever une tension

Proposer un circuit permettant d' lever une tension d'un facteur k .

$$k > 1$$

Mission 3 - Limiter une tension

Rappeler le fonctionnement d'une diode.

D crire le fonctionnement du montage suivant :

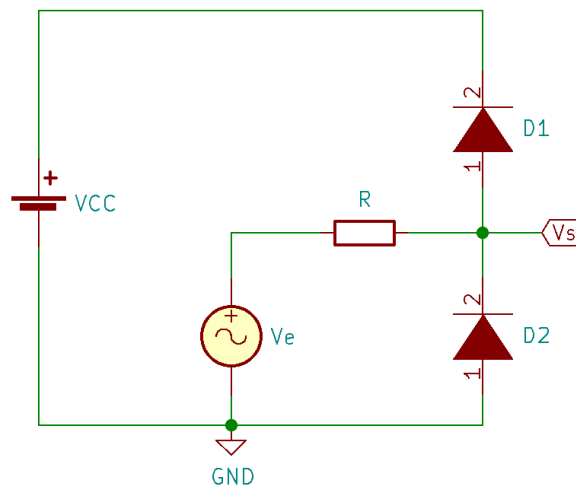
**Mission 4 - Amplifier un signal**

Proposer un circuit permettant d'amplifier un signal de $27dB$, tout en garantissant une bande-passante de $400kHz$.

On utilisera des amplificateurs lin aires int gr s de type TL071 (documentation partielle donn e en annexe).

Mission 5 - Additionner des signaux

On se propose d'étudier le circuit suivant :

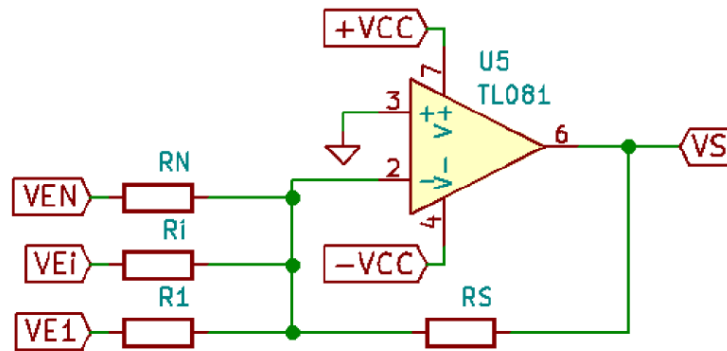

Mission 6 - Mettre en forme un capteur de température

On se propose d'étudier le circuit suivant :

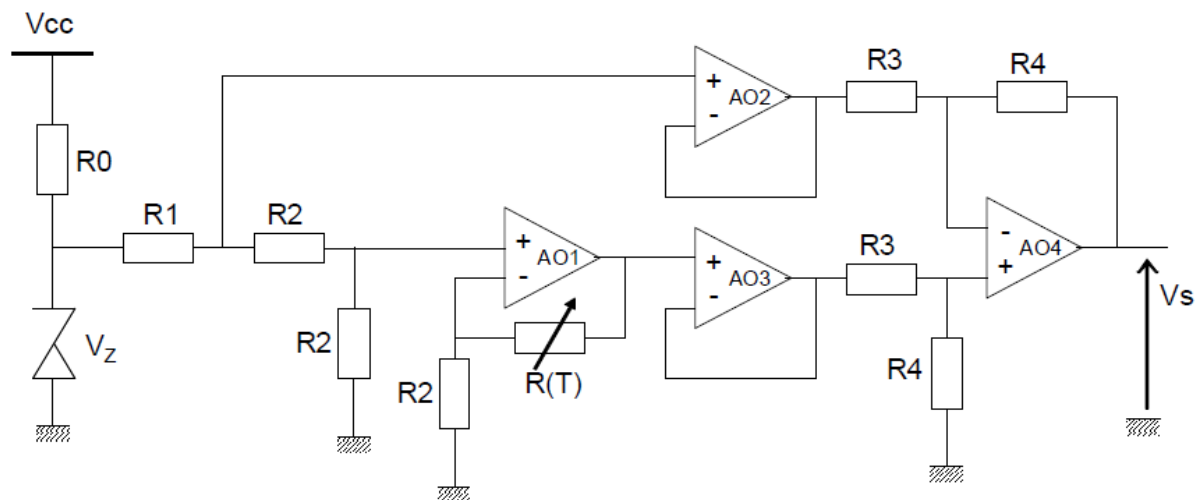

La thermistance utilisée est de type PT100. La relation entre sa résistance (en Ohms) et la température (en °C) est la suivante :

$$R(T) = 100 (1 + 3.90810^{-3}T - 5.80210^{-7}T^2)$$

Une partie de la documentation de diodes Zener est fournie en annexe.

TL08xx JFET-Input Operational Amplifiers

1 Features

- Low Power Consumption: 1.4 mA/ch Typical
- Wide Common-Mode and Differential Voltage Ranges
- Low Input Bias Current: 30 pA Typical
- Low Input Offset Current: 5 pA Typical
- Output Short-Circuit Protection
- Low Total Harmonic Distortion: 0.003% Typical
- High Input Impedance: JFET Input Stage
- Latch-Up-Free Operation
- High Slew Rate: 13 V/ μ s Typical
- Common-Mode Input Voltage Range Includes V_{CC+}

2 Applications

- Tablets
- White goods
- Personal electronics
- Computers

3 Description

The TL08xx JFET-input operational amplifier family is designed to offer a wider selection than any previously developed operational amplifier family. Each of these JFET-input operational amplifiers incorporates well-matched, high-voltage JFET and bipolar transistors in a monolithic integrated circuit. The devices feature high slew rates, low input bias and offset currents, and low offset-voltage temperature coefficient.

Device Information⁽¹⁾

PART NUMBER	PACKAGE	BODY SIZE (NOM)
TL084xD	SOIC (14)	8.65 mm × 3.91 mm
TL08xxFK	LCCC (20)	8.89 mm × 8.89 mm
TL084xJ	CDIP (14)	19.56 mm × 6.92 mm
TL084xN	PDIP (14)	19.3 mm × 6.35 mm
TL084xNS	SO (14)	10.3 mm × 5.3 mm
TL084xPW	TSSOP (14)	5.0 mm × 4.4 mm

(1) For all available packages, see the orderable addendum at the end of the data sheet.

Schematic Symbol

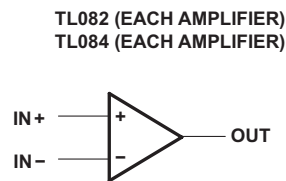
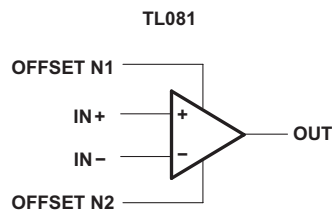

6 Specifications

6.1 Absolute Maximum Ratings

over operating free-air temperature range (unless otherwise noted)⁽¹⁾

				MIN	MAX	UNIT
V _{CC+}	Supply voltage ⁽²⁾			18		V
V _{CC-}				-18		
V _{ID}	Differential input voltage ⁽³⁾			±30		V
V _I	Input voltage ⁽²⁾⁽⁴⁾			±15		V
Duration of output short circuit ⁽⁵⁾				Unlimited		
Continuous total power dissipation				See Dissipation Rating Table		
T _A	Operating free-air temperature	TL08_C TL08_AC TL08_BC		0	70	°C
		TL08_I		-40	85	
		TL084Q		-40	125	
		TL08_M		-55	125	
Operating virtual junction temperature				150		°C
T _C	Case temperature for 60 seconds	FK package	TL08_M	260		°C
	Lead temperature 1,6 mm (1/16 inch) from case for 10 seconds	J or JG package	TL08_M	300		
T _{stg}	Storage temperature			-65	150	°C

- (1) Stresses beyond those listed under *Absolute Maximum Ratings* may cause permanent damage to the device. These are stress ratings only, and functional operation of the device at these or any other conditions beyond those indicated under *Recommended Operating Conditions* is not implied. Exposure to absolute-maximum-rated conditions for extended periods may affect device reliability.
- (2) All voltage values, except differential voltages, are with respect to the midpoint between V_{CC+} and V_{CC-}.
- (3) Differential voltages are at IN+, with respect to IN-.
- (4) The magnitude of the input voltage must never exceed the magnitude of the supply voltage or 15 V, whichever is less.
- (5) The output may be shorted to ground or to either supply. Temperature and/or supply voltages must be limited to ensure that the dissipation rating is not exceeded.

6.2 ESD Ratings

			VALUE	UNIT
V _(ESD)	Electrostatic discharge	Human body model (HBM), per ANSI/ESDA/JEDEC JS-001 ⁽¹⁾	1000	V
		Charged-device model (CDM), per JEDEC specification JESD22-C101 ⁽²⁾	1500	

- (1) JEDEC document JEP155 states that 500-V HBM allows safe manufacturing with a standard ESD control process.
- (2) JEDEC document JEP157 states that 250-V CDM allows safe manufacturing with a standard ESD control process.

6.3 Recommended Operating Conditions

over operating free-air temperature range (unless otherwise noted)

				MIN	MAX	UNIT
V _{CC+}	Supply voltage			5	15	V
V _{CC-}	Supply voltage			-5	-15	V
V _{CM}	Common-mode voltage			V _{CC-} + 4	V _{CC+} - 4	V
T _A	Ambient temperature	TL08xM		-55	125	°C
		TL08xQ		-40	125	
		TL08xI		-40	85	
		TL08xC		0	70	

Electrical Characteristics for TL08xC, TL08xxC, and TL08xl (continued)

 $V_{CC\pm} = \pm 15\text{ V}$ (unless otherwise noted)

PARAMETER	TEST CONDITIONS	$T_A^{(1)}$	TL081C, TL082C, TL084C			TL081AC, TL082AC, TL084AC			TL081BC, TL082BC, TL084BC			TL081I, TL082I, TL084I			UNIT
			MIN	TYP	MAX	MIN	TYP	MAX	MIN	TYP	MAX	MIN	TYP	MAX	
I_{CC}	Supply current (each amplifier) $V_O = 0$, No load	25°C		1.4	2.8		1.4	2.8		1.4	2.8		1.4	2.8	mA
V_{O1}/V_{O2}	Crosstalk attenuation $A_{VD} = 100$	25°C		120			120			120			120		dB

6.6 Electrical Characteristics for TL08xM and TL084x

 $V_{CC\pm} = \pm 15\text{ V}$ (unless otherwise noted)

PARAMETER	TEST CONDITIONS ⁽¹⁾	T_A	TL081M, TL082M			TL084Q, TL084M			UNIT
			MIN	TYP	MAX	MIN	TYP	MAX	
V_{IO}	Input offset voltage $V_O = 0$, $R_S = 50\ \Omega$	25°C		3	6		3	9	mV
		Full range			9		15		
α_{VIO}	Temperature coefficient of input offset voltage $V_O = 0$, $R_S = 50\ \Omega$	Full range		18			18	$\mu\text{V}/^\circ\text{C}$	
I_{IO}	Input offset current ⁽²⁾ $V_O = 0$	25°C		5	100		5	100	pA
		125°C			20		20	nA	
I_{IB}	Input bias current ⁽²⁾ $V_O = 0$	25°C		30	200		30	200	pA
		125°C			50		50	nA	
V_{ICR}	Common-mode input voltage range	25°C	± 11	-12 to 15		± 11	-12 to 15	V	
V_{OM}	Maximum peak output voltage swing	$R_L = 10\ \text{k}\Omega$		± 12	± 13.5		± 12	± 13.5	V
		$R_L \geq 10\ \text{k}\Omega$		± 12			± 12		
		$R_L \geq 2\ \text{k}\Omega$	Full range		± 10	± 12		± 10	
A_{VD}	Large-signal differential voltage amplification $V_O = \pm 10\ \text{V}$, $R_L \geq 2\ \text{k}\Omega$	25°C		25	200		25	200	V/mV
		Full range		15			15		
B_1	Unity-gain bandwidth	25°C		3			3	MHz	
r_i	Input resistance	25°C		10^{12}			10^{12}	Ω	
CMRR	Common-mode rejection ratio $V_{IC} = V_{ICRmin}$, $V_O = 0$, $R_S = 50\ \Omega$	25°C		80	86		80	86	dB
k_{SVR}	Supply-voltage rejection ratio ($\Delta V_{CC\pm}/\Delta V_{IO}$) $V_{CC} = \pm 15\ \text{V}$ to $\pm 9\ \text{V}$, $V_O = 0$, $R_S = 50\ \Omega$	25°C		80	86		80	86	dB
I_{CC}	Supply current (each amplifier) $V_O = 0$, No load	25°C		1.4	2.8		1.4	2.8	mA
V_{O1}/V_{O2}	Crosstalk attenuation $A_{VD} = 100$	25°C		120			120		dB

(1) All characteristics are measured under open-loop conditions, with zero common-mode input voltage, unless otherwise specified.

(2) Input bias currents of a FET-input operational amplifier are normal junction reverse currents, which are temperature sensitive, as shown in Figure 13. Pulse techniques must be used that maintain the junction temperatures as close to the ambient temperature as possible.

6.7 Operating Characteristics

 $V_{CC\pm} = \pm 15\ \text{V}$, $T_A = 25^\circ\text{C}$ (unless otherwise noted)

PARAMETER	TEST CONDITIONS	MIN	TYP	MAX	UNIT
SR	$V_I = 10\ \text{V}$, $R_L = 2\ \text{k}\Omega$, $C_L = 100\ \text{pF}$, See Figure 19	8 ⁽¹⁾	13		V/ μs
	$V_I = 10\ \text{V}$, $R_L = 2\ \text{k}\Omega$, $C_L = 100\ \text{pF}$, $T_A = -55^\circ\text{C}$ to 125°C , See Figure 19	5 ⁽¹⁾			

(1) On products compliant to MIL-PRF-38535, this parameter is not production tested.

6.9 Typical Characteristics

Data at high and low temperatures are applicable only within the rated operating free-air temperature ranges of the various devices. The Figure numbers referenced in the following graphs are located in [Parameter Measurement Information](#).

Table 1. Table of Graphs

			Figure
V_{OM}	Maximum peak output voltage	versus Frequency versus Free-air temperature versus Load resistance versus Supply voltage	Figure 1, Figure 2, Figure 3 Figure 4 Figure 5 Figure 6
A_{VD}	Large-signal differential voltage amplification	versus Free-air temperature versus Load resistance	Figure 7 Figure 8
	Differential voltage amplification	versus Frequency with feed-forward compensation	Figure 9
P_D	Total power dissipation	versus Free-air temperature	Figure 10
I_{CC}	Supply current	versus Free-air temperature	Figure 11
		versus Supply voltage	Figure 12
I_{IB}	Input bias current	versus Free-air temperature	Figure 13
	Large-signal pulse response	versus Time	Figure 14
V_O	Output voltage	versus Elapsed time	Figure 15
CMRR	Common-mode rejection ratio	versus Free-air temperature	Figure 16
V_n	Equivalent input noise voltage	versus Frequency	Figure 17
THD	Total harmonic distortion	versus Frequency	Figure 18

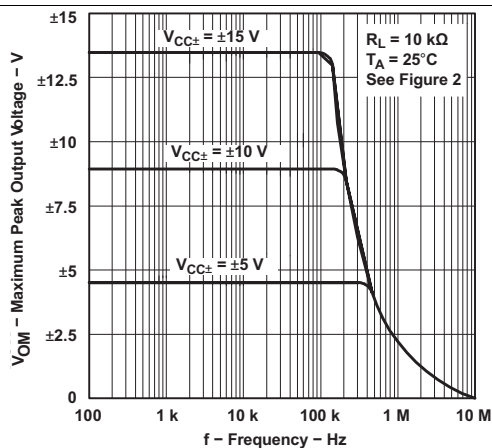

Figure 1. Maximum Peak Output Voltage vs Frequency

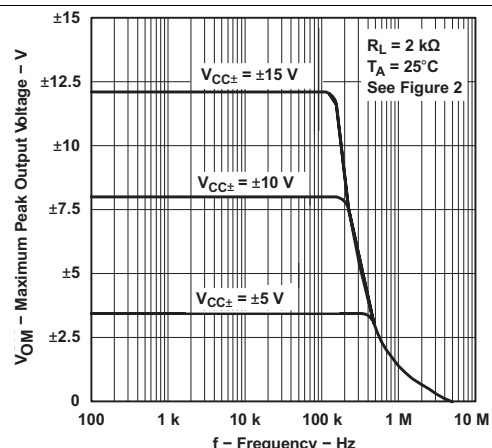

Figure 2. Maximum Peak Output Voltage vs Frequency



Zener Diodes



FEATURES

- Silicon planar power Zener diodes
- For use in stabilizing and clipping circuits with high power rating
- Standard Zener voltage tolerance is $\pm 5\%$
- Material categorization: for definitions of compliance please see www.vishay.com/doc?99912



RoHS
COMPLIANT
HALOGEN
FREE

APPLICATIONS

- Voltage stabilization

LINKS TO ADDITIONAL RESOURCES



PRIMARY CHARACTERISTICS		
PARAMETER	VALUE	UNIT
V _Z range nom.	3.3 to 75	V
Test current I _{ZT}	3.3 to 76	mA
V _Z specification	Thermal equilibrium	
Circuit configuration	Single	

ORDERING INFORMATION			
DEVICE NAME	ORDERING CODE	TAPED UNITS PER REEL	MINIMUM ORDER QUANTITY
1N4728A to 1N4761A	1N4728A to 1N4761A -series-TR	5000 per 13" reel	25 000/box
1N4728A to 1N4761A	1N4728A to 1N4761A-series-TAP	5000 per ammpack (52 mm tape)	25 000/box

PACKAGE				
PACKAGE NAME	WEIGHT	MOLDING COMPOUND FLAMMABILITY RATING	MOISTURE SENSITIVITY LEVEL	SOLDERING CONDITIONS
DO-41 (DO-204AL)	310 mg	UL 94 V-0	MSL level 1 (according J-STD-020)	Peak temperature max. 260 °C

ABSOLUTE MAXIMUM RATINGS (T _{amb} = 25 °C, unless otherwise specified)					
PARAMETER	TEST CONDITION	SYMBOL	VALUE	UNIT	
Power dissipation	Valid provided that leads at a distance of 4 mm from case are kept at ambient temperature	P _{tot}	1300	mW	
Zener current		I _Z	P _V /V _Z	mA	
Thermal resistance junction to ambient air	Valid provided that leads at a distance of 4 mm from case are kept at ambient temperature	R _{thJA}	110	K/W	
Junction temperature		T _j	175	°C	
Storage temperature range		T _{stg}	-65 to +175	°C	
Forward voltage (max.)	I _F = 200 mA	V _F	1.2	V	



ELECTRICAL CHARACTERISTICS (T _{amb} = 25 °C, unless otherwise specified)									
PART NUMBER	ZENER VOLTAGE RANGE ⁽¹⁾	TEST CURRENT		REVERSE LEAKAGE CURRENT		DYNAMIC RESISTANCE f = 1 kHz		SURGE CURRENT ⁽³⁾	REGULATOR CURRENT ⁽²⁾
	V _Z at I _{ZT1}	I _{ZT1}	I _{ZT2}	I _R at V _R		Z _{ZT} at I _{ZT1}	Z _{ZK} at I _{ZT2}	I _R	I _{ZM}
	V	mA	mA	μA	V	Ω		mA	mA
	NOM.			MAX.		TYP.	MAX.		MAX.
1N4728A	3.3	76	1	100	1	10	400	1380	276
1N4729A	3.6	69	1	100	1	10	400	1260	252
1N4730A	3.9	64	1	50	1	9	400	1190	234
1N4731A	4.3	58	1	10	1	9	400	1070	217
1N4732A	4.7	53	1	10	1	8	500	970	193
1N4733A	5.1	49	1	10	1	7	550	890	178
1N4734A	5.6	45	1	10	2	5	600	810	162
1N4735A	6.2	41	1	10	3	2	700	730	146
1N4736A	6.8	37	1	10	4	3.5	700	660	133
1N4737A	7.5	34	0.5	10	5	4	700	605	121
1N4738A	8.2	31	0.5	10	6	4.5	700	550	110
1N4739A	9.1	28	0.5	10	7	5	700	500	100
1N4740A	10	25	0.25	10	7.6	7	700	454	91
1N4741A	11	23	0.25	5	8.4	8	700	414	83
1N4742A	12	21	0.25	5	9.1	9	700	380	76
1N4743A	13	19	0.25	5	9.9	10	700	344	69
1N4744A	15	17	0.25	5	11.4	14	700	304	61
1N4745A	16	15.5	0.25	5	12.2	16	700	285	57
1N4746A	18	14	0.25	5	13.7	20	750	250	50
1N4747A	20	12.5	0.25	5	15.2	22	750	225	45
1N4748A	22	11.5	0.25	5	16.7	23	750	205	41
1N4749A	24	10.5	0.25	5	18.2	25	750	190	38
1N4750A	27	9.5	0.25	5	20.6	35	750	170	34
1N4751A	30	8.5	0.25	5	22.8	40	1000	150	30
1N4752A	33	7.5	0.25	5	25.1	45	1000	135	27
1N4753A	36	7	0.25	5	27.4	50	1000	125	25
1N4754A	39	6.5	0.25	5	29.7	60	1000	115	23
1N4755A	43	6	0.25	5	32.7	70	1500	110	22
1N4756A	47	5.5	0.25	5	35.8	80	1500	95	19
1N4757A	51	5	0.25	5	38.8	95	1500	90	18
1N4758A	56	4.5	0.25	5	42.6	110	2000	80	16
1N4759A	62	4	0.25	5	47.1	125	2000	70	14
1N4760A	68	3.7	0.25	5	51.7	150	2000	65	13
1N4761A	75	3.3	0.25	5	56	175	2000	60	12

Notes

- (1) Based on DC measurement at thermal equilibrium while maintaining the lead temperature (T_L) at 30 °C + 1 °C, 9.5 mm (3/8") from the diode body
- (2) Valid provided that electrodes at a distance of 4 mm from case are kept at ambient temperature
- (3) t_p = 10 ms.