

Ingénierie Electronique pour le Traitement de l'Information

TD 11

Asservir un système

Julien VILLEMEJANE



Paris-Saclay



Saint-Étienne



Bordeaux

- **Systeme bouclé**

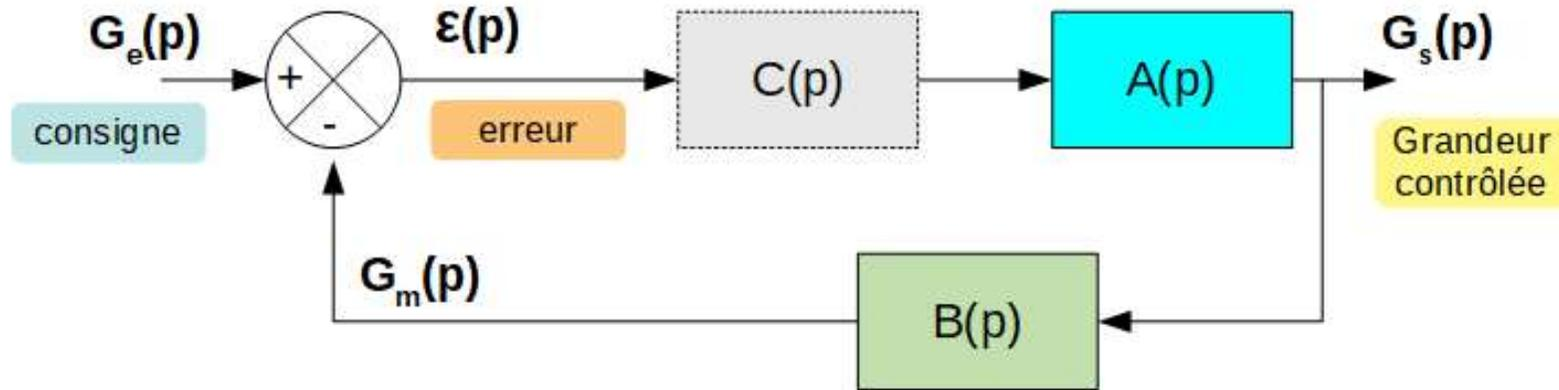

- Exercice 1 / Q1 – boucle ouverte

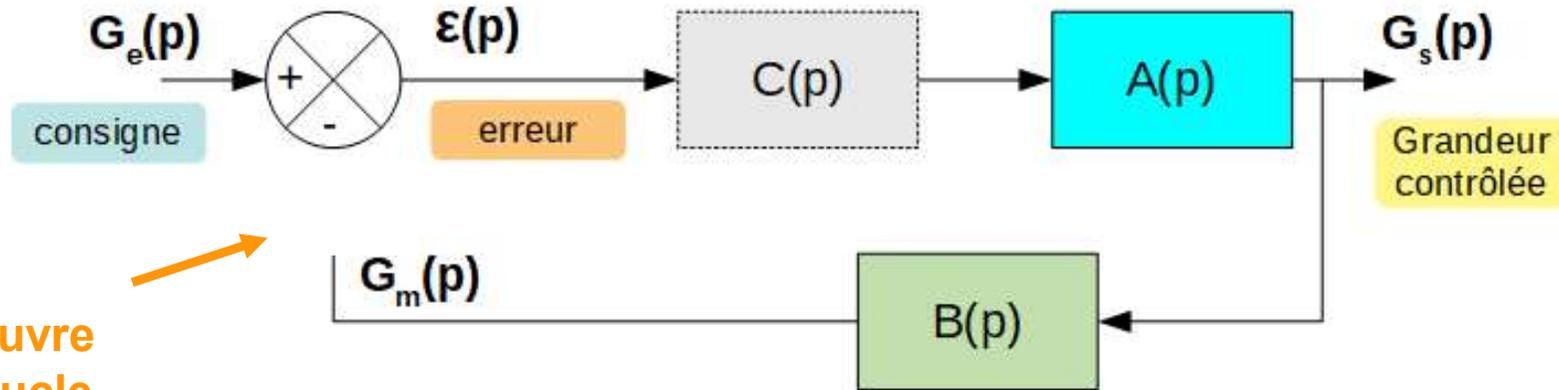

• Exercice 1 / Q1 – boucle ouverte

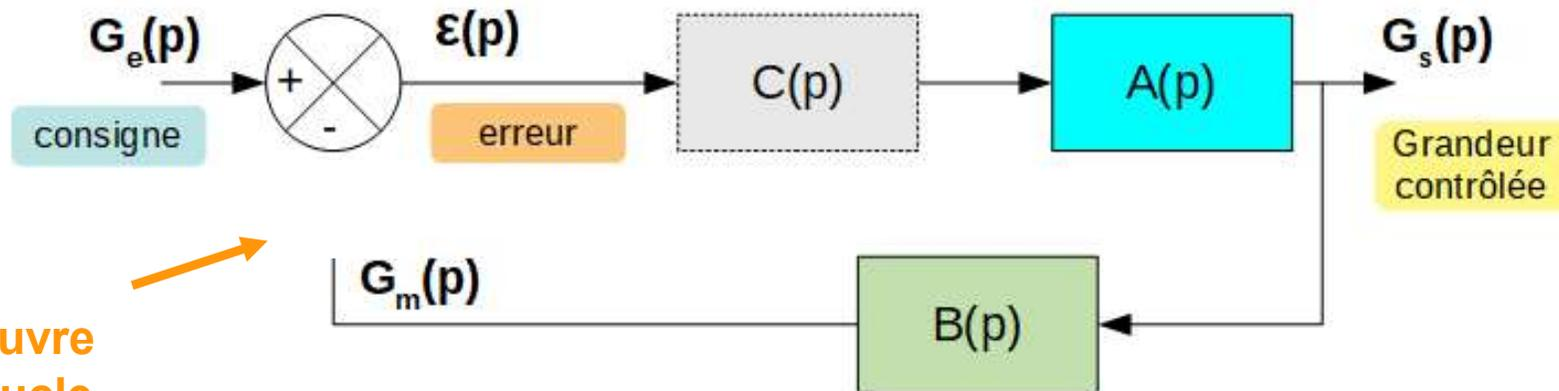

On ouvre
la boucle

$$TF_{BO}(p) = \frac{G_m(p)}{\varepsilon(p)} = C(p) \cdot A(p) \cdot B(p)$$



• Exercice 1 / Q2

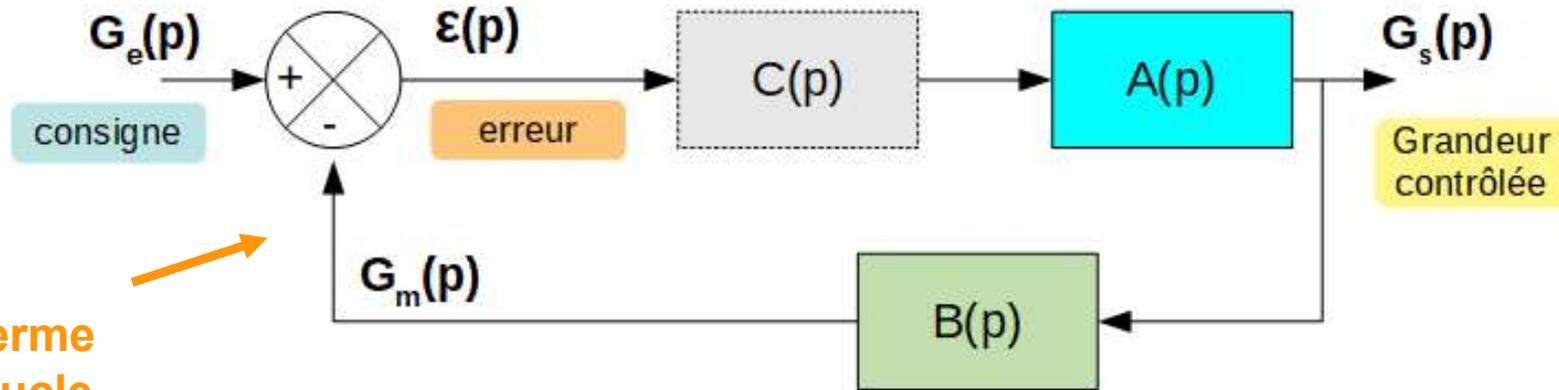

On ferme
la boucle



• Exercice 1 / Q2

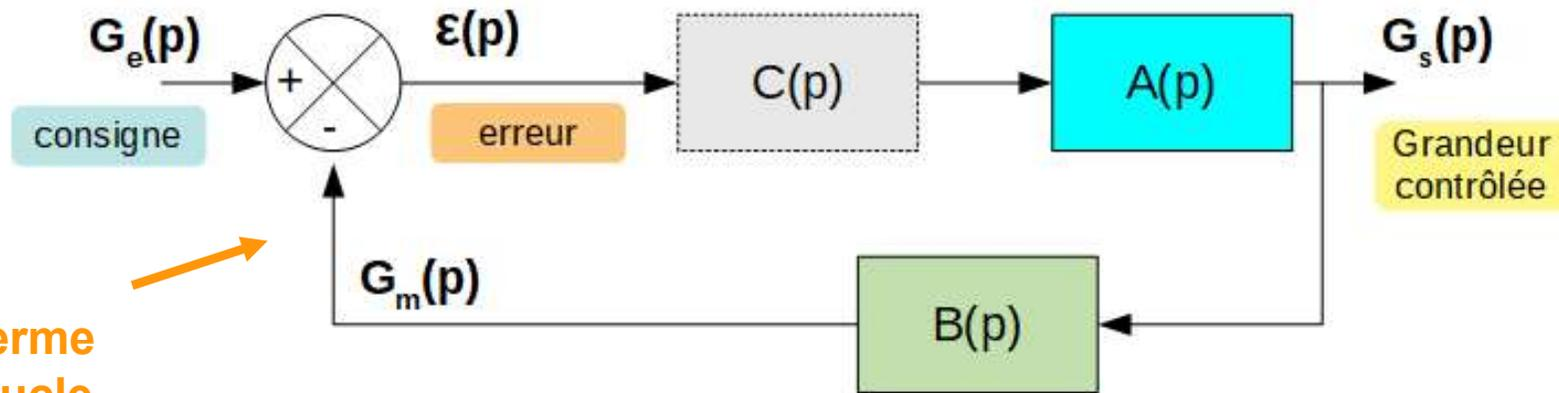

On ferme
la boucle

$$TF_{BF}(p) = \frac{G_s(p)}{G_e(p)} = \frac{A(p) \cdot C(p)}{1 + A(p) \cdot C(p) \cdot B(p)}$$



• Exercice 1 / Q3

$$TF_{BF}(p) = \frac{G_s(p)}{G_e(p)} = \frac{A(p) \cdot C(p)}{1 + L(p)}$$

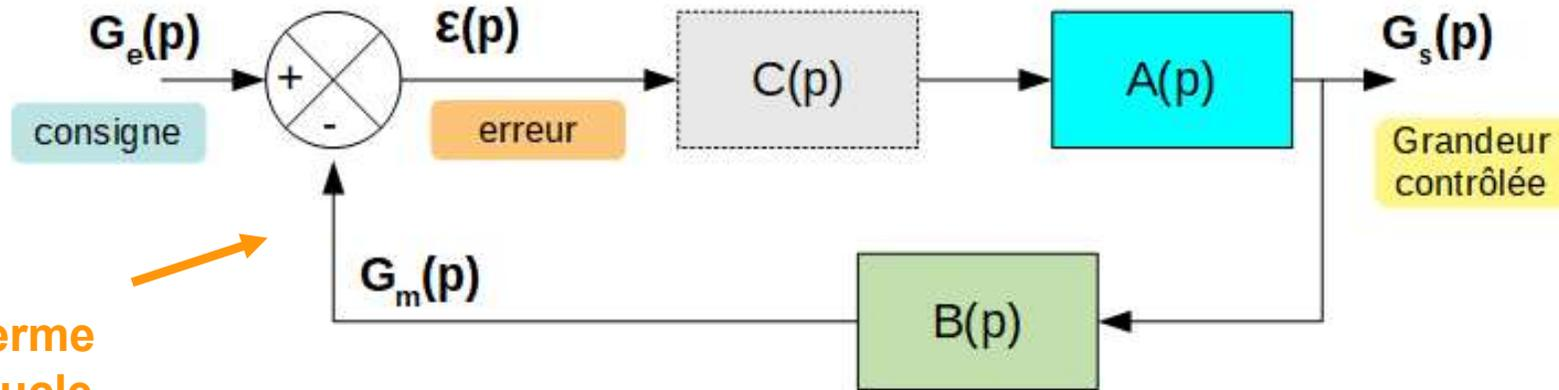

On ferme
la boucle

$$TF_{BF}(p) = \frac{G_s(p)}{G_e(p)} = \frac{A(p) \cdot C(p)}{1 + A(p) \cdot C(p) \cdot B(p)}$$



• Exercice 1 / Stabilité ?

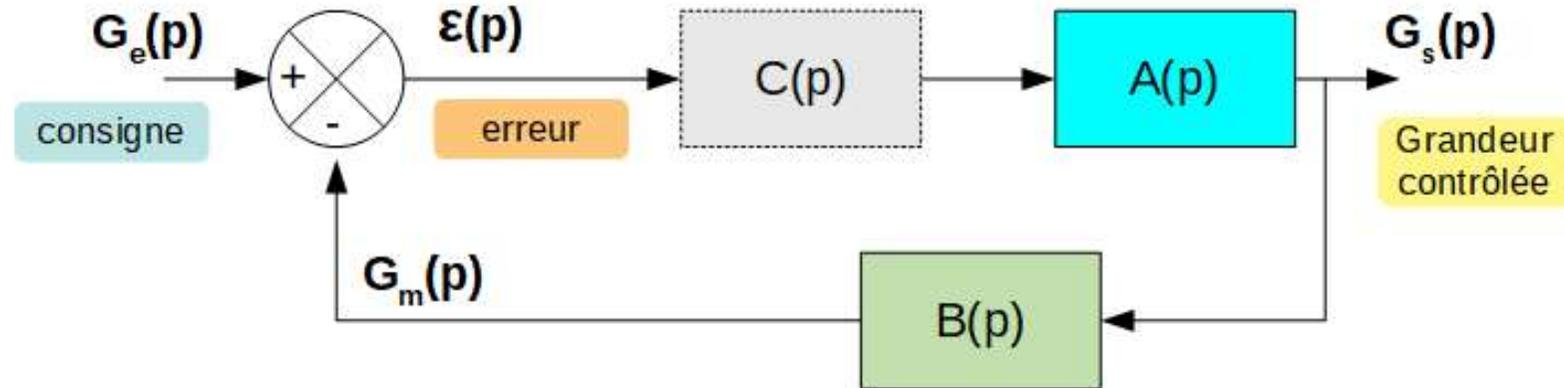

$$TF_{BF}(p) = \frac{G_s(p)}{G_e(p)} = \frac{A(p) \cdot C(p)}{1 + L(p)}$$



• Exercice 1 / Stabilité ? Lieu de Nyquist

$$TF_{BF}(p) = \frac{G_s(p)}{G_e(p)} = \frac{A(p) \cdot C(p)}{1 + L(p)}$$

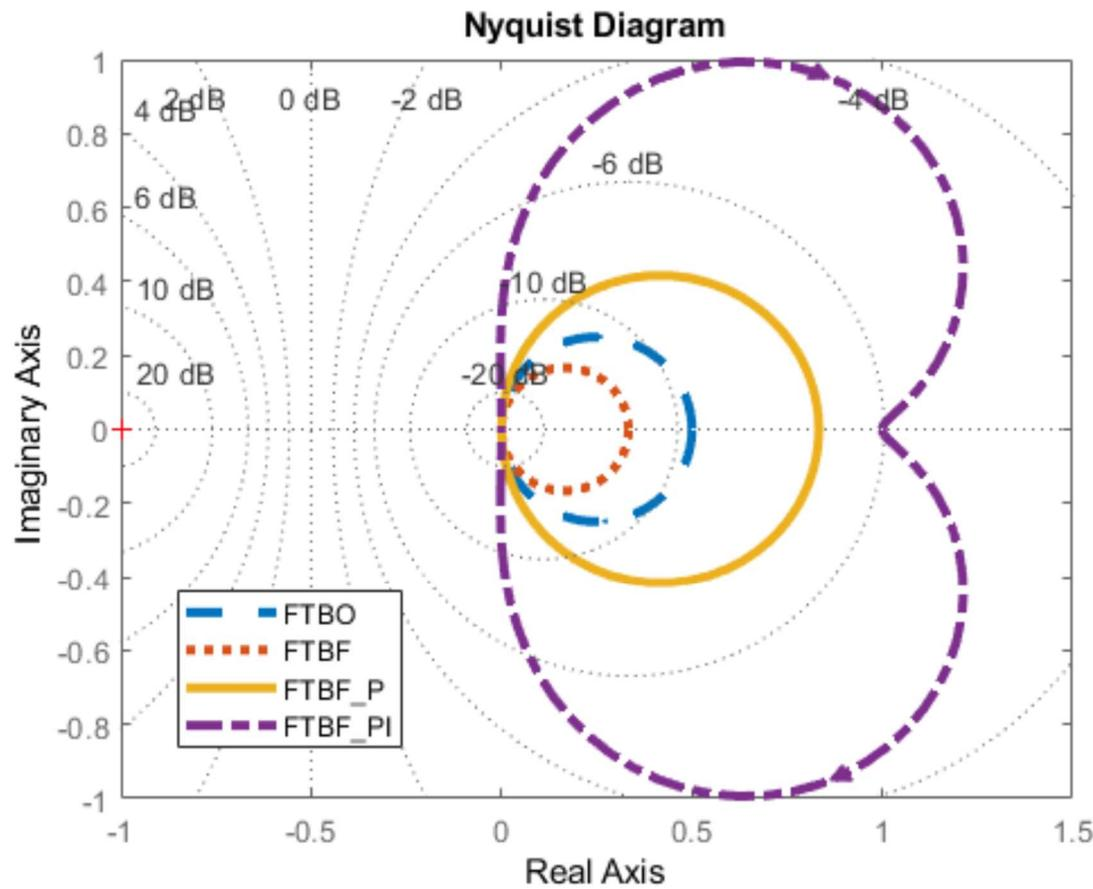

• Exercice 1 / Stabilité ?

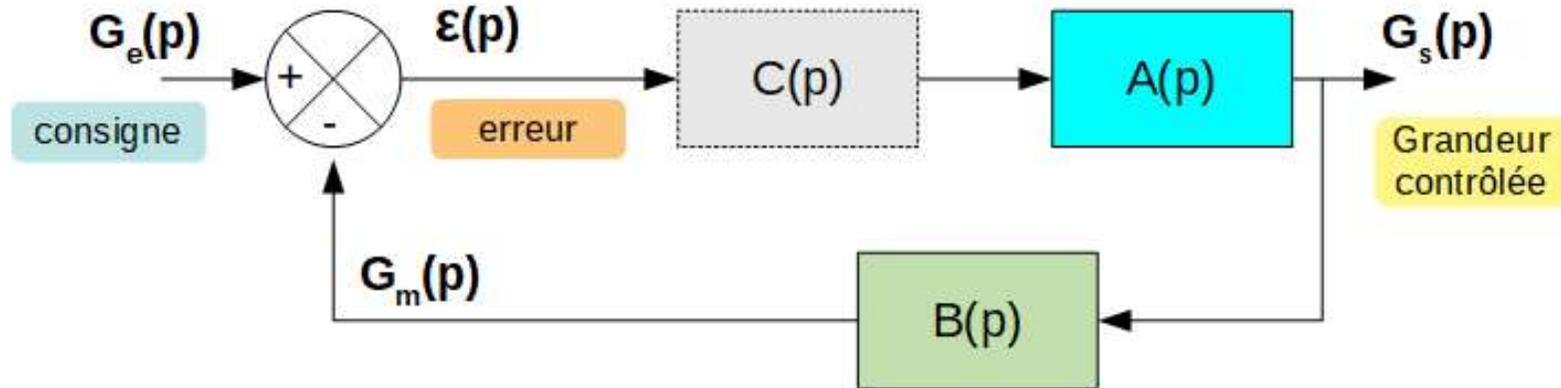

$$T_{FTBF}(p) = N(p)/D(p)$$

$$T_{FTBF}(p) = \sum_k \frac{c_k}{p - a_k}$$

TL⁻¹
➔

$$s(t) = \sum_k c_k \cdot e^{a_k \cdot t}$$



• Exercice 1 / Stabilité / Q1

$$TF_{BF}(p) = \frac{G_s(p)}{G_e(p)} = \frac{A(p) \cdot C(p)}{1 + L(p)}$$

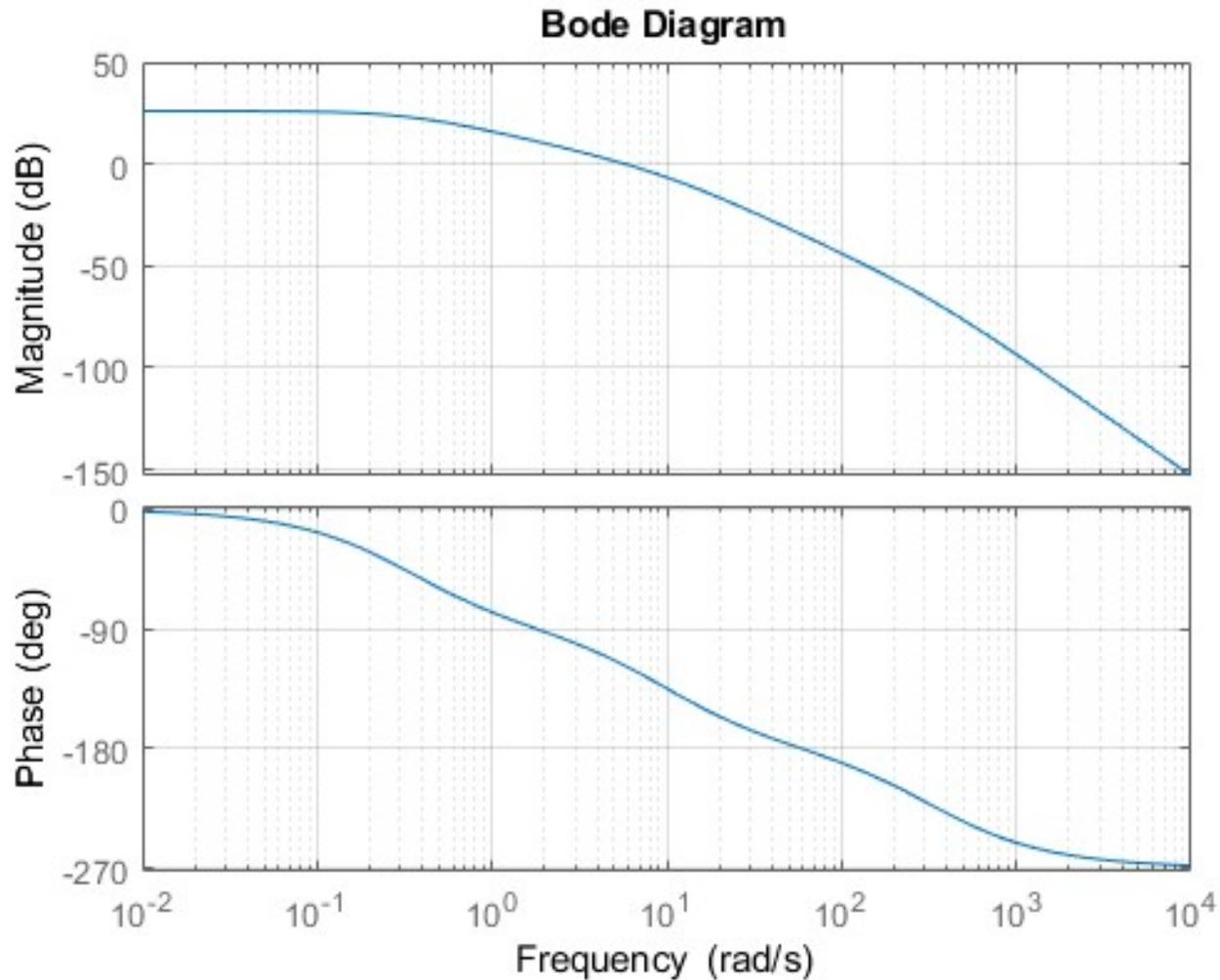

• Exercice 1 / Stabilité / Q1

$$TF_{BF}(p) = \frac{G_s(p)}{G_e(p)} = \frac{A(p) \cdot C(p)}{1 + L(p)}$$

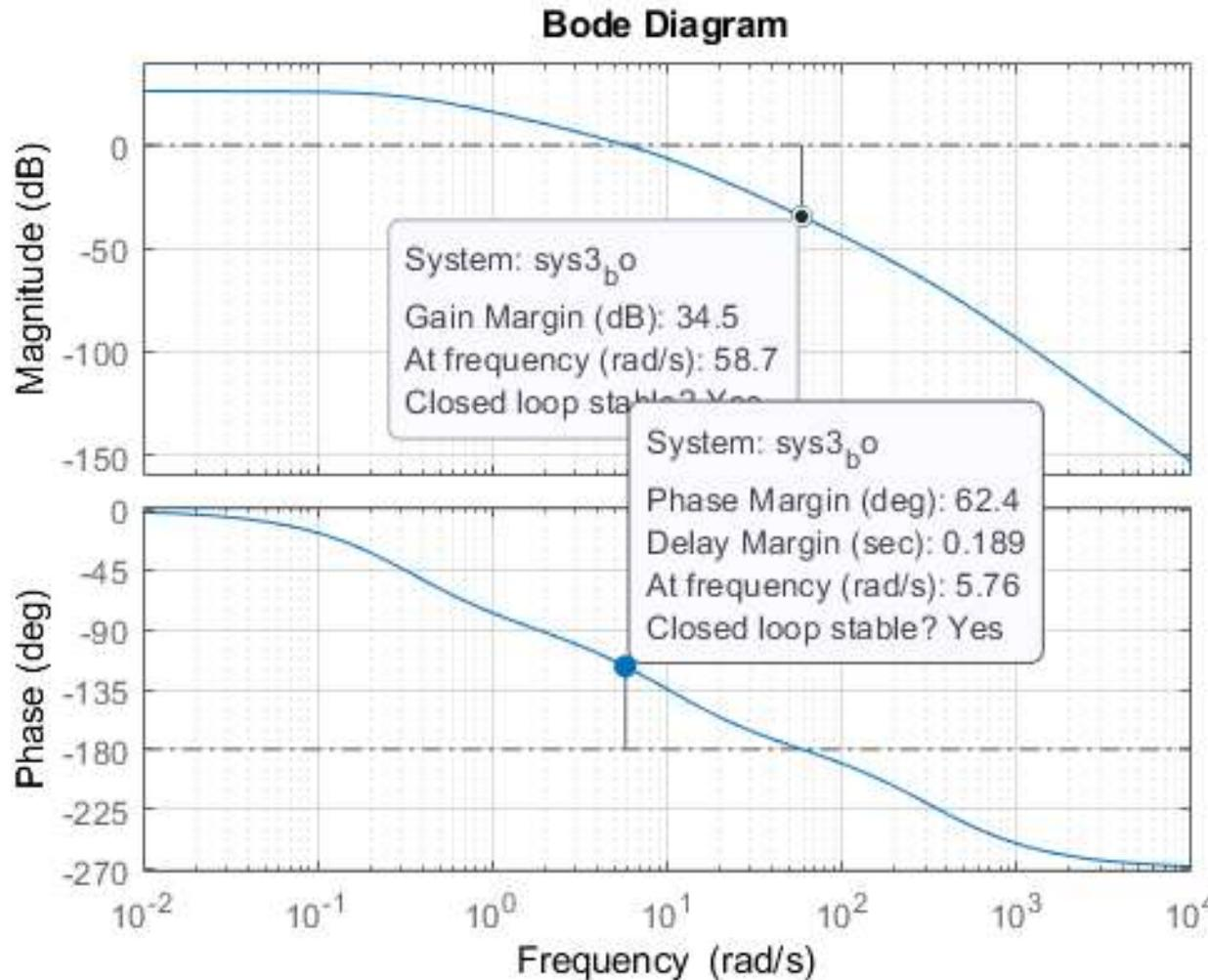

Systeme stable
➔ marge de phase positive

marge de gain = gain supplémentaire maximum à donner au système en BO sans risquer de le rendre instable en BF



- Exercice 1 / Stabilité / Q2

$$TF_{BF}(p) = \frac{G_s(p)}{G_e(p)} = \frac{A(p) \cdot C(p)}{1 + L(p)}$$

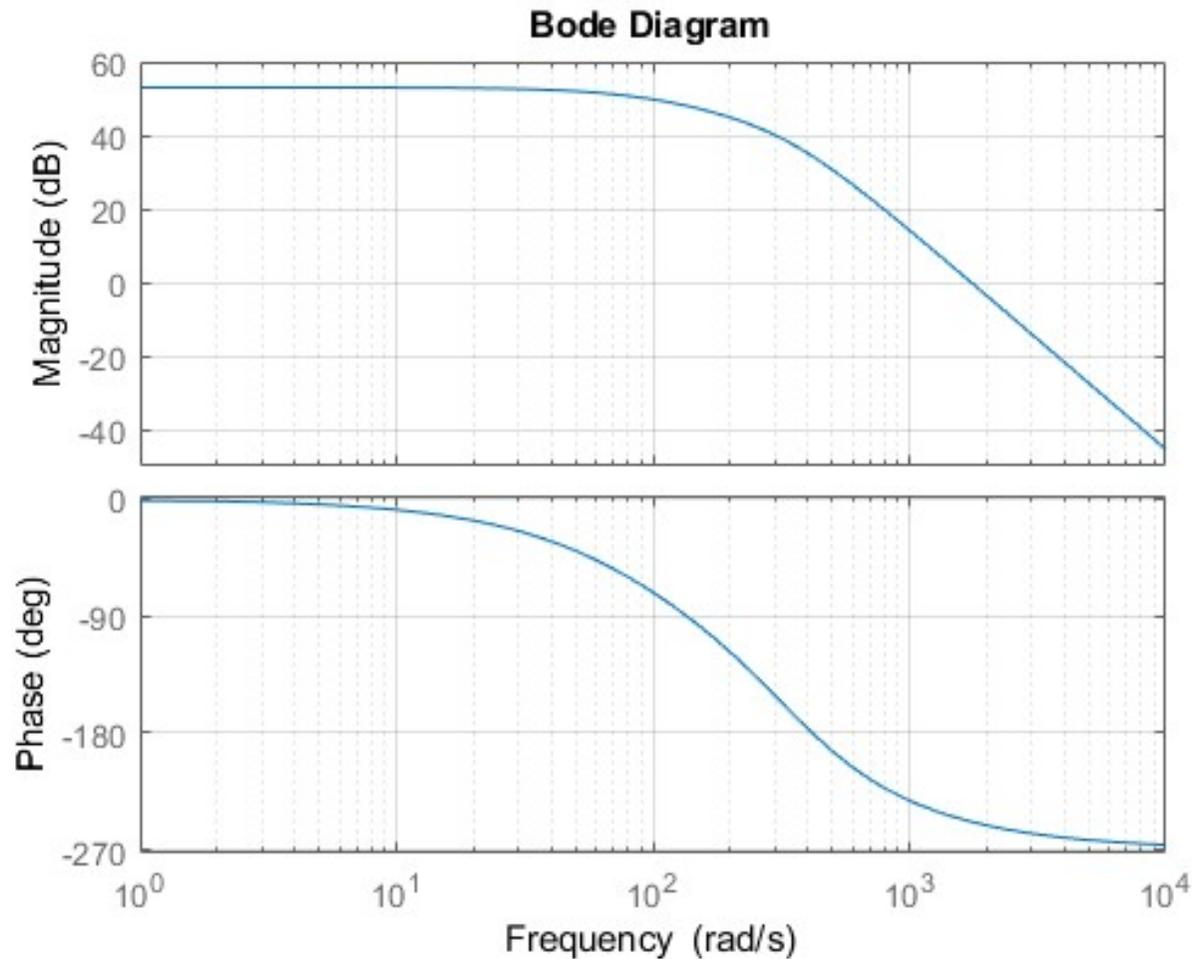

• Exercice 1 / Stabilité / Q2

$$TF_{BF}(p) = \frac{G_s(p)}{G_e(p)} = \frac{A(p) \cdot C(p)}{1 + L(p)}$$

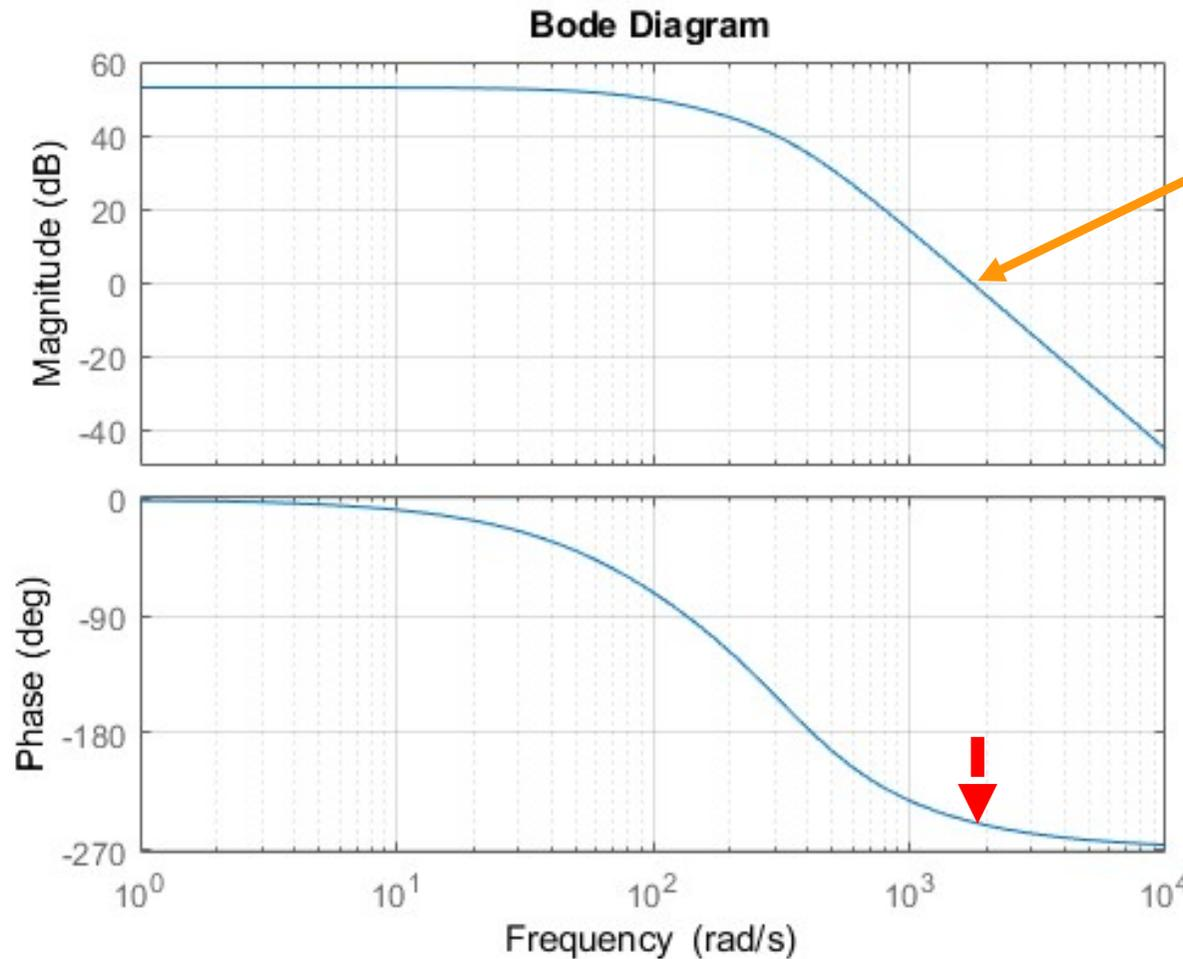

G = 0dB

marge de phase
négative !!

➡ **Systeme instable**



• Exercice 1 / Correction

$$C(p) = 1$$

$$C(p) = G$$

$$C(p) = G + 1/(\tau_i \cdot p)$$

$$H(p) = \frac{H_0}{1 + \tau \cdot p}$$

$$H_0 = 0.5$$

$$\tau = 2 \cdot 10^{-3}$$

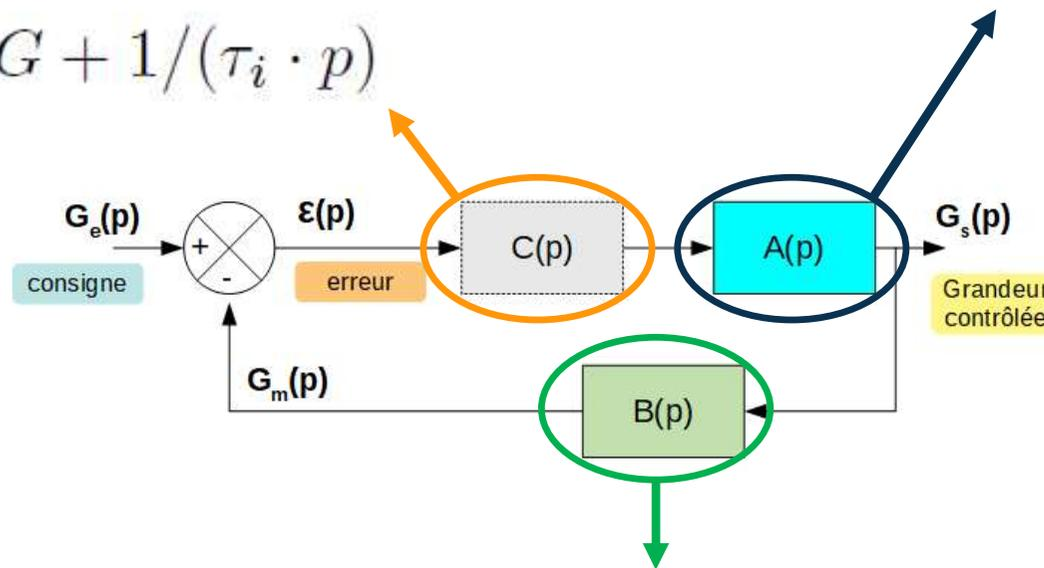

$$B(p) = 1$$



• Exercice 1 / Correction

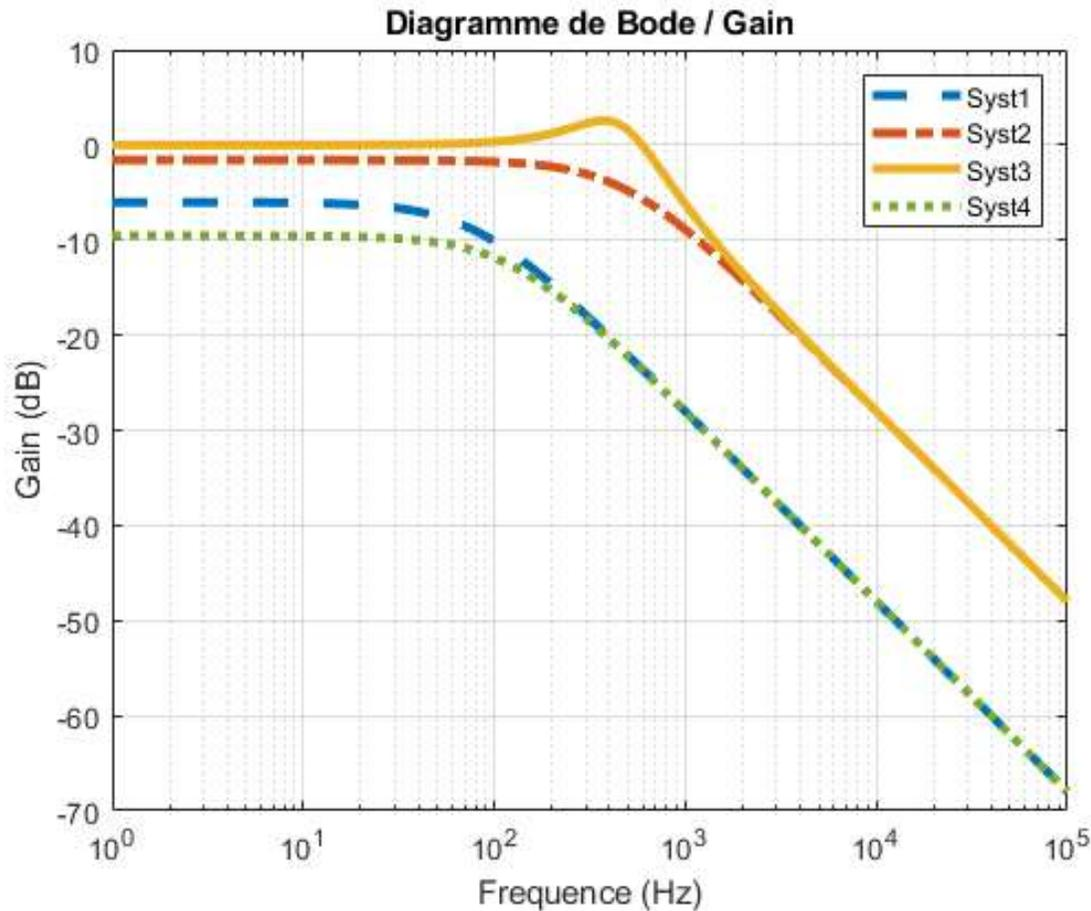

$$H(p) = \frac{H_0}{1 + \tau \cdot p}$$

$$C(p) = 1$$

$$C(p) = G$$

$$C(p) = G + 1/(\tau_i \cdot p)$$



• Exercice 1 / Correction / Boucle ouverte

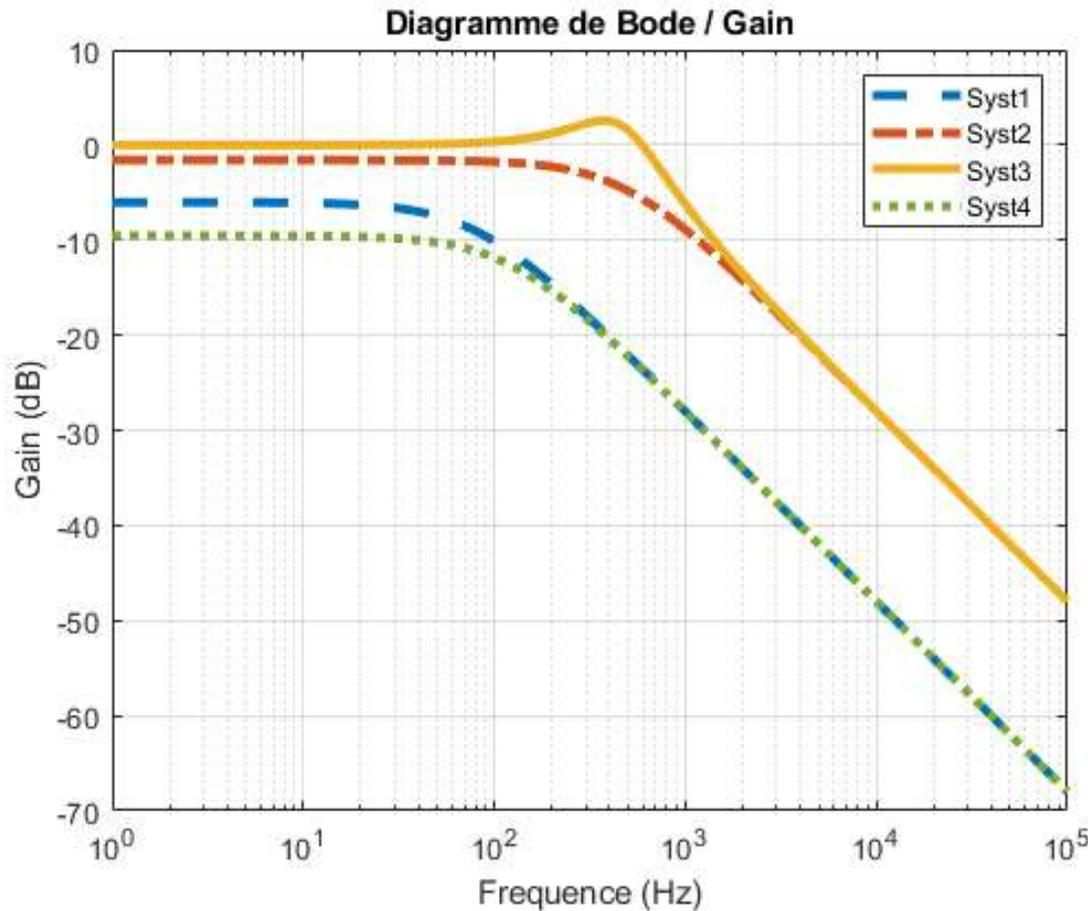

Boucle ouverte

$$H(p) = \frac{H_0}{1 + \tau \cdot p}$$

Premier ordre

$$G_0 = -6 \text{ dB}$$



• Exercice 1 / Correction / Boucle ouverte

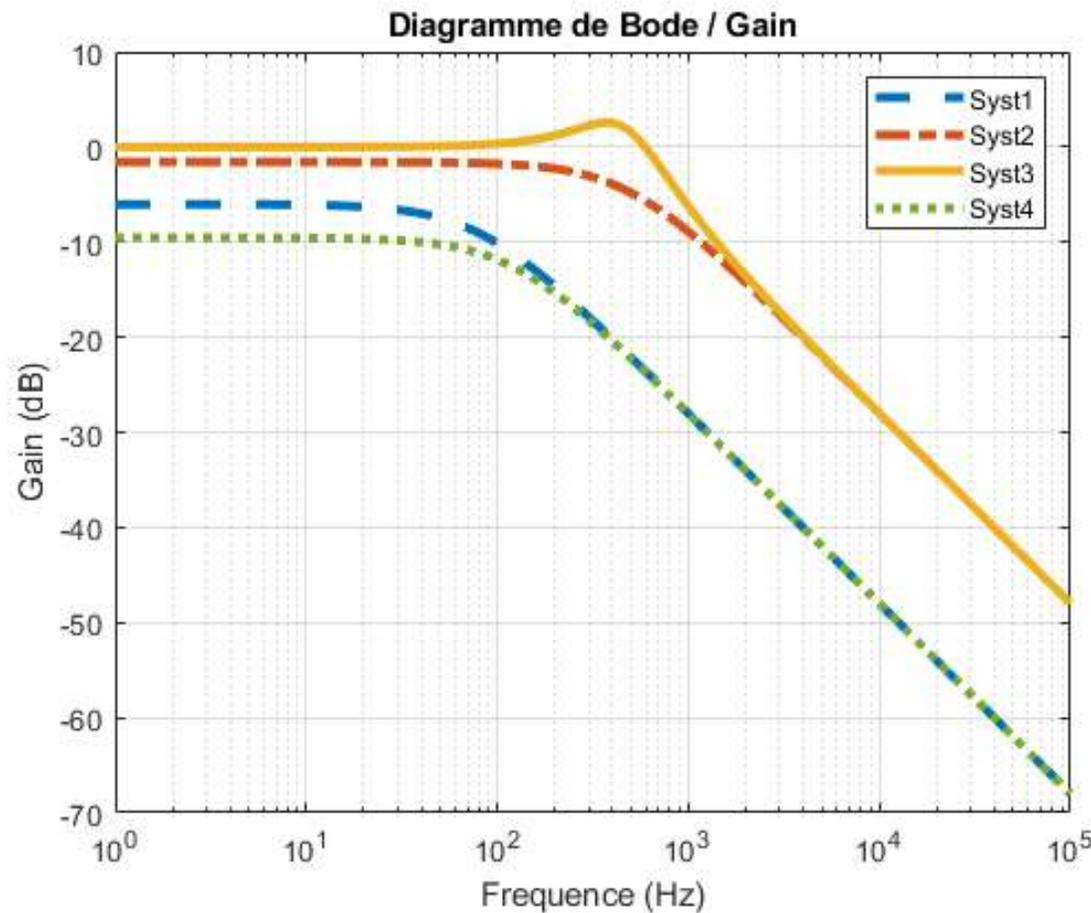

Boucle ouverte

$$H(p) = \frac{H_0}{1 + \tau \cdot p}$$

Premier ordre

$$G_0 = -6 \text{ dB}$$

Systeme 1



• Exercice 1 / Correction / Boucle fermée

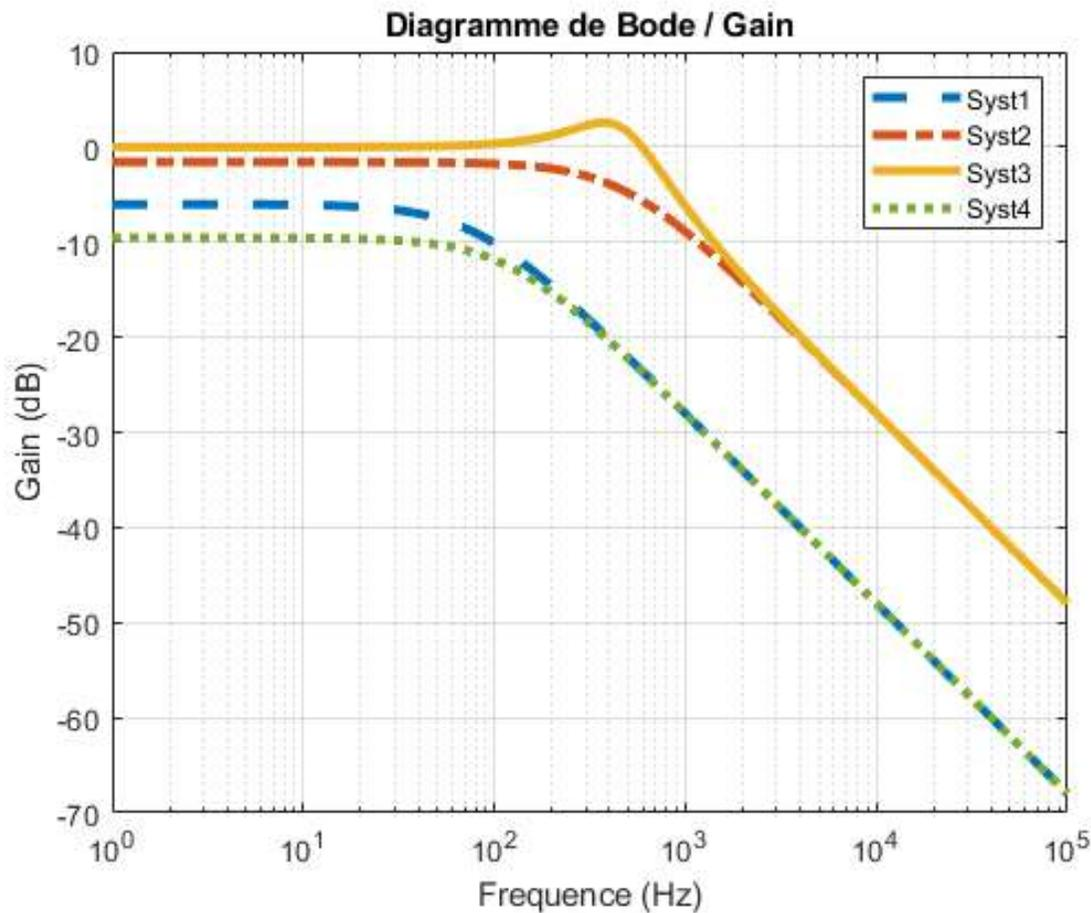

Boucle fermée

$$C(p) = 1$$

$$FTBF(p) = \frac{H_0}{1 + H_0} \cdot \frac{1}{1 + \frac{\tau \cdot p}{1 + H_0}}$$



• Exercice 1 / Correction / Boucle fermée

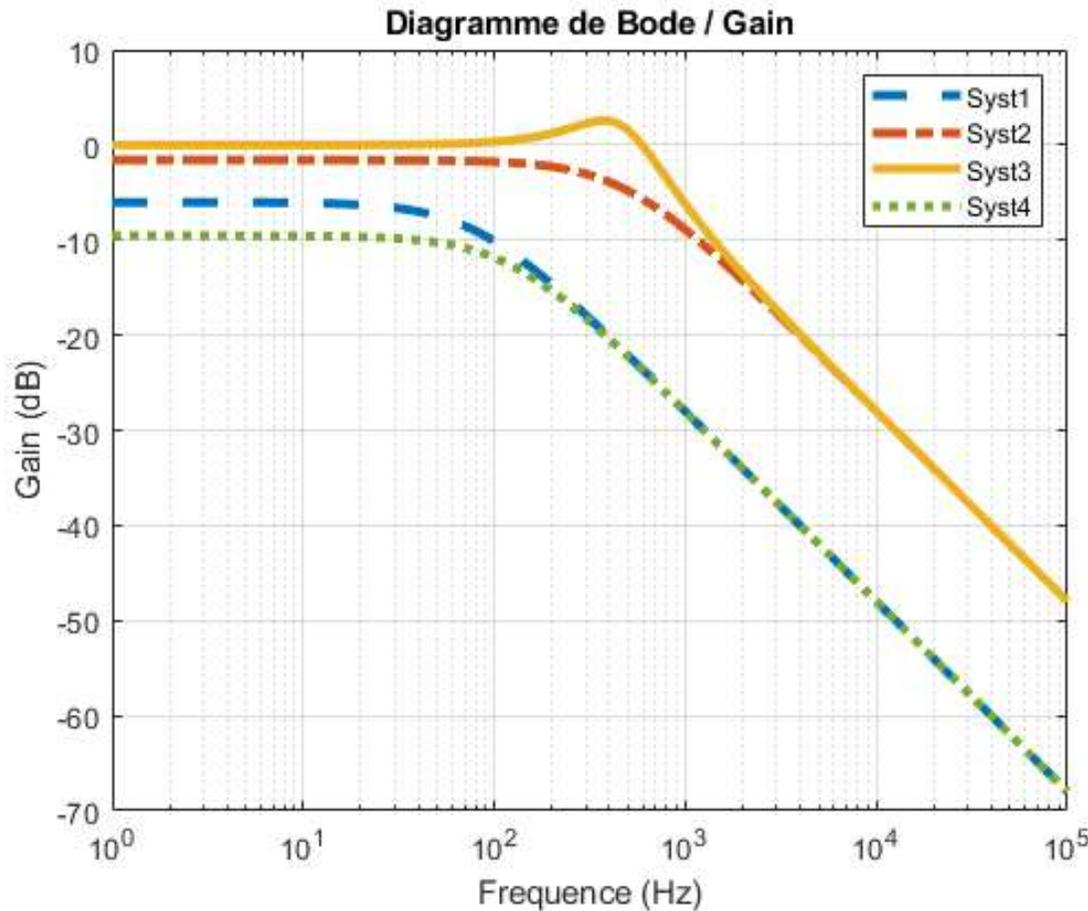

Boucle fermée

$$C(p) = 1$$

$$FTBF(p) = \frac{H_0}{1 + H_0} \cdot \frac{1}{1 + \frac{\tau \cdot p}{1 + H_0}}$$

Premier ordre

$$FTBF_0 = H_0 / (1 + H_0)$$

$$\tau_B F = \tau / (1 + H_0) < \tau$$

$$G_0 = -9.6 \text{ dB}$$

Systeme 4



• Exercice 1 / Correction / Boucle fermée proportionnelle

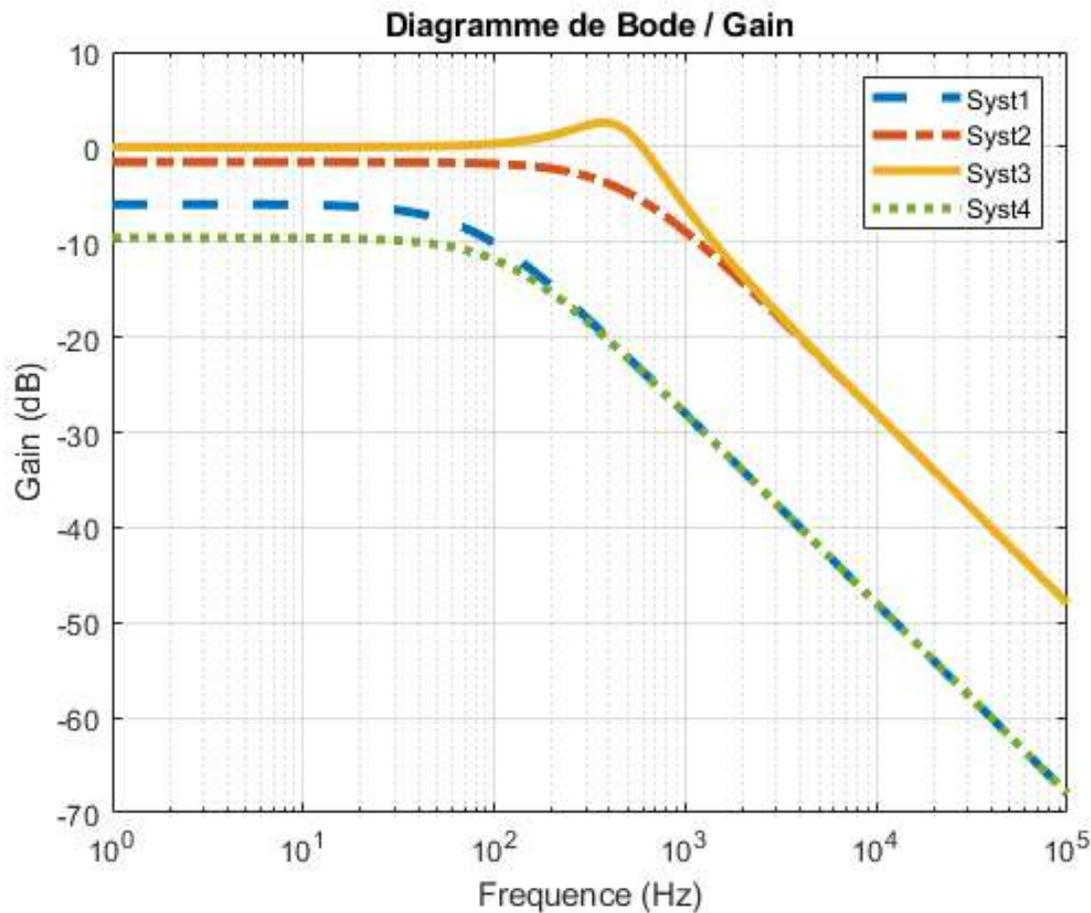

Boucle fermée / cor P

$$C(p) = G$$

$$FTBF(p) = \frac{G \cdot H_0}{1 + G \cdot H_0} \cdot \frac{1}{1 + \frac{\tau \cdot p}{1 + G \cdot H_0}}$$



• Exercice 1 / Correction / Boucle fermée proportionnelle

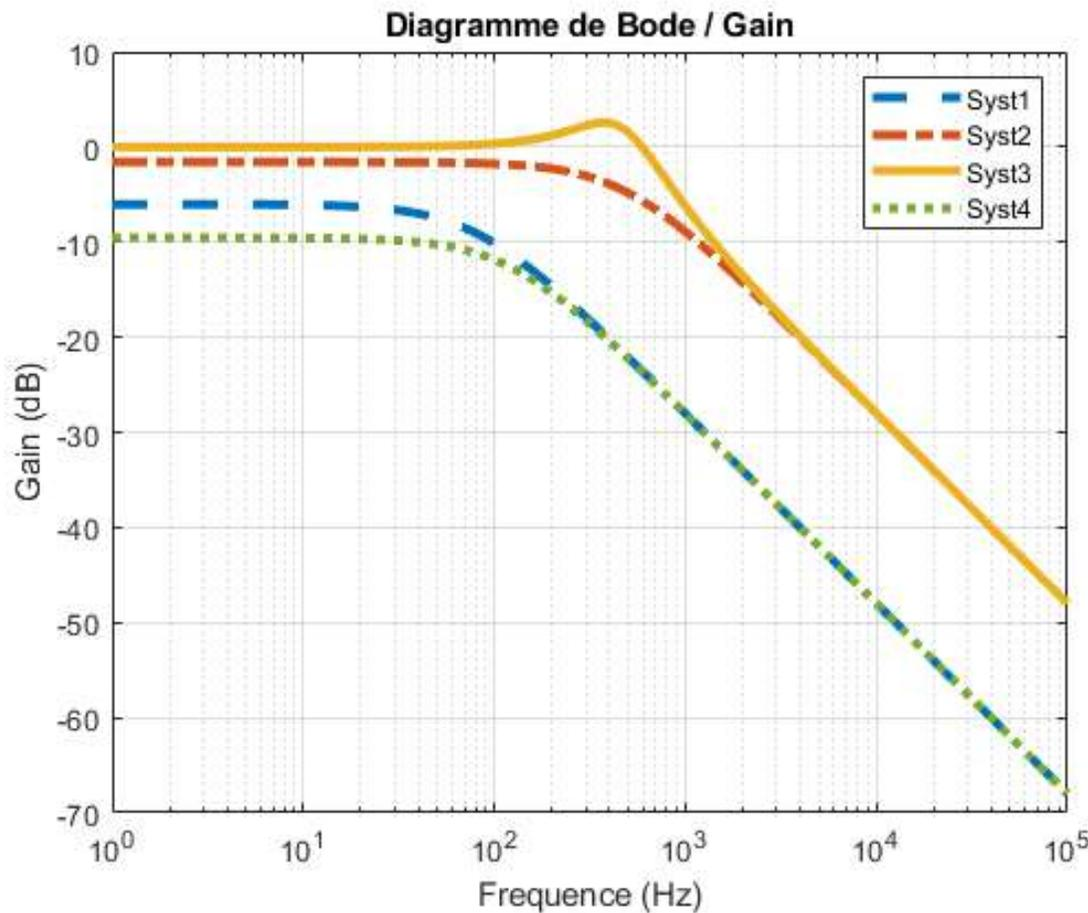

Boucle fermée / cor P

$$C(p) = G$$

$$FTBF(p) = \frac{G \cdot H_0}{1 + G \cdot H_0} \cdot \frac{1}{1 + \frac{\tau \cdot p}{1 + G \cdot H_0}}$$

Premier ordre

$$FTBF_0 = G \cdot H_0 / (1 + G \cdot H_0)$$

$$\tau_{BF} = \tau / (1 + G \cdot H_0) < \tau$$

$$G_0 = -1.5 \text{ dB}$$

Systeme 2



• Exercice 1 / Correction / Boucle fermée intégrale

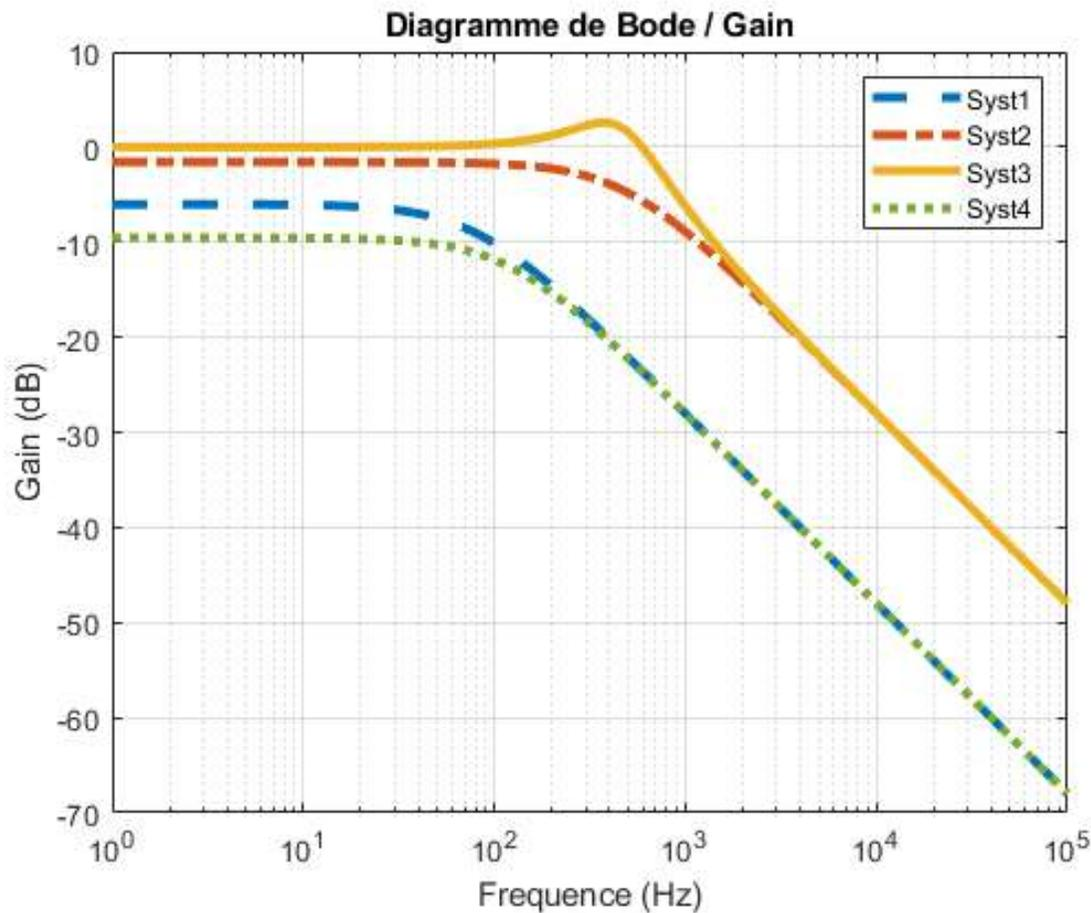

Boucle fermée / cor PI

$$C(p) = G + 1/(\tau_i \cdot p)$$

$$C(p) \cdot H(p) = \frac{H_0 \cdot G \cdot \tau_i \cdot p + H_0}{\tau_i \cdot p + \tau \cdot \tau_i \cdot p}$$



• Exercice 1 / Correction / Boucle fermée intégrale

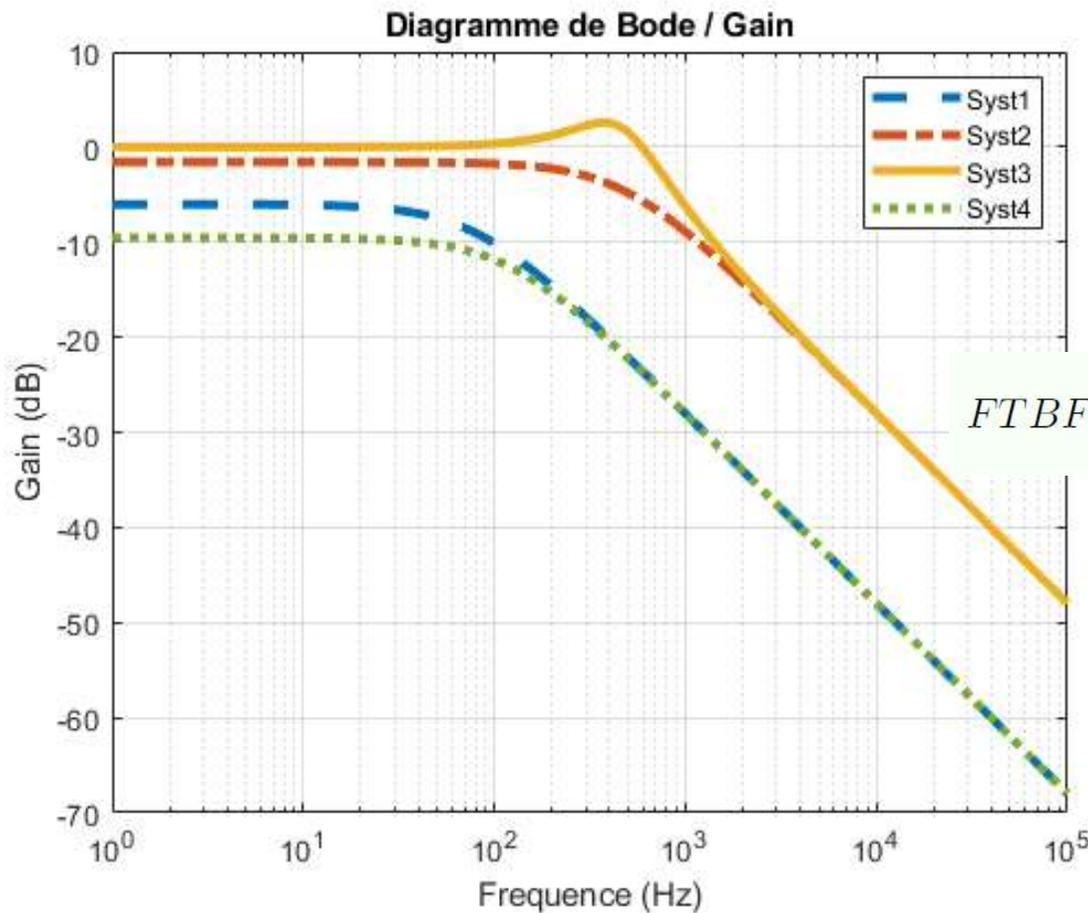

Boucle fermée / cor PI

$$C(p) = G + 1/(\tau_i \cdot p)$$

$$C(p) \cdot H(p) = \frac{H_0 \cdot G \cdot \tau_i \cdot p + H_0}{\tau_i \cdot p + \tau \cdot \tau_i \cdot p}$$

$$FTBF(p) = \frac{G \cdot \tau_i \cdot p}{1 + (1/H_0 + K) \cdot \tau_i \cdot p + \tau \cdot \tau_i p^2 / H_0}$$

Second ordre

Systeme 3



$$H_0 = 0.5$$

• Exercice 1 / Correction / Réponse à un échelon ?

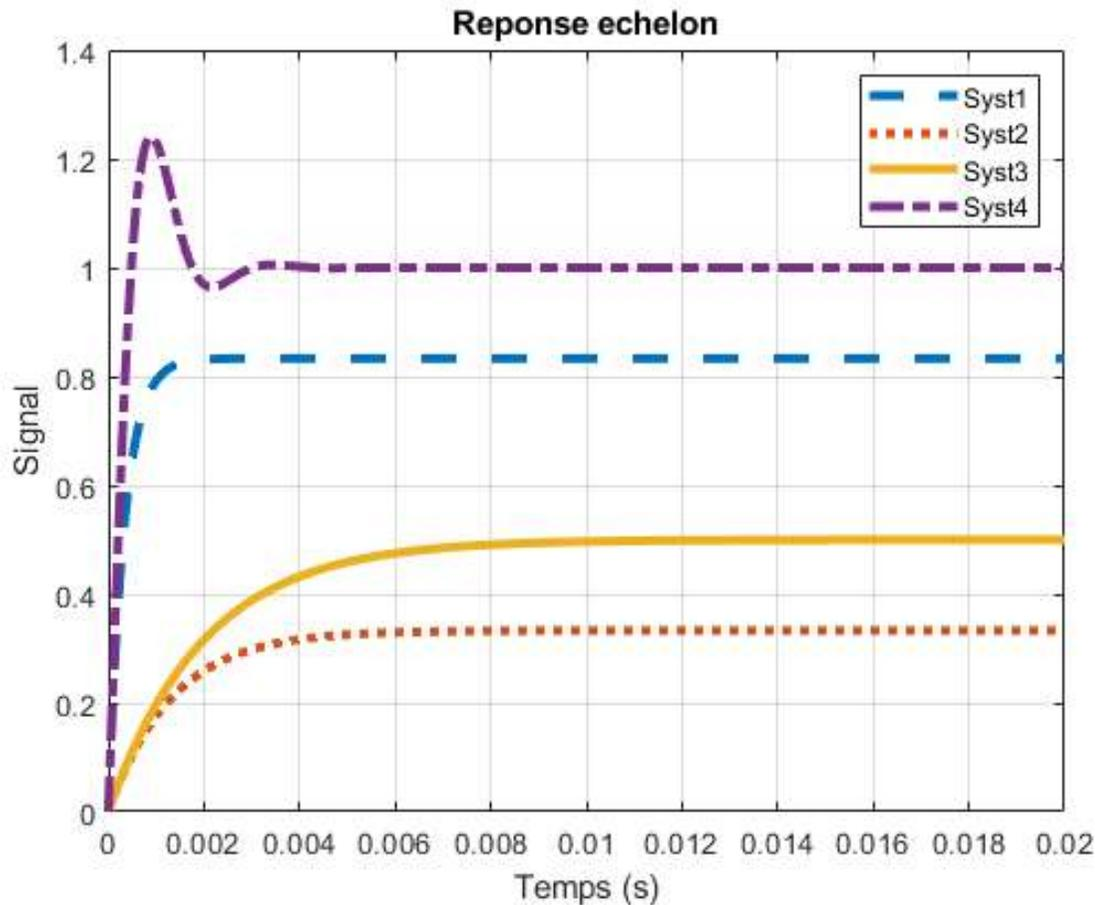

$$H(p) = \frac{H_0}{1 + \tau \cdot p}$$

$$C(p) = 1$$

$$C(p) = G$$

$$C(p) = G + 1/(\tau_i \cdot p)$$



$$H_0 = 0.5$$

• Exercice 1 / Correction / Réponse à un échelon ?

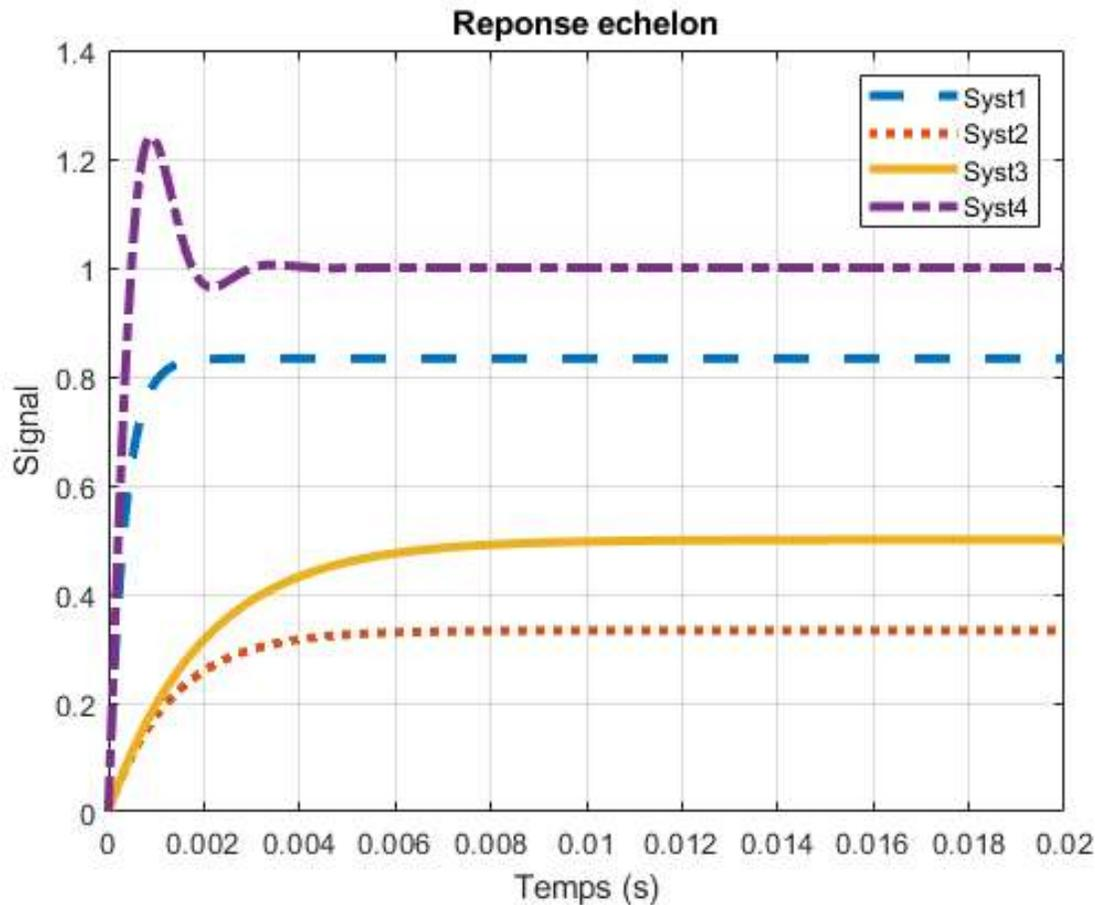

$$H(p) = \frac{H_0}{1 + \tau \cdot p}$$

$$C(p) = 1$$

$$C(p) = G$$

$$C(p) = G + 1/(\tau_i \cdot p)$$



$$H_0 = 0.5$$

• Exercice 1 / Lieu de Nyquist / Stabilité

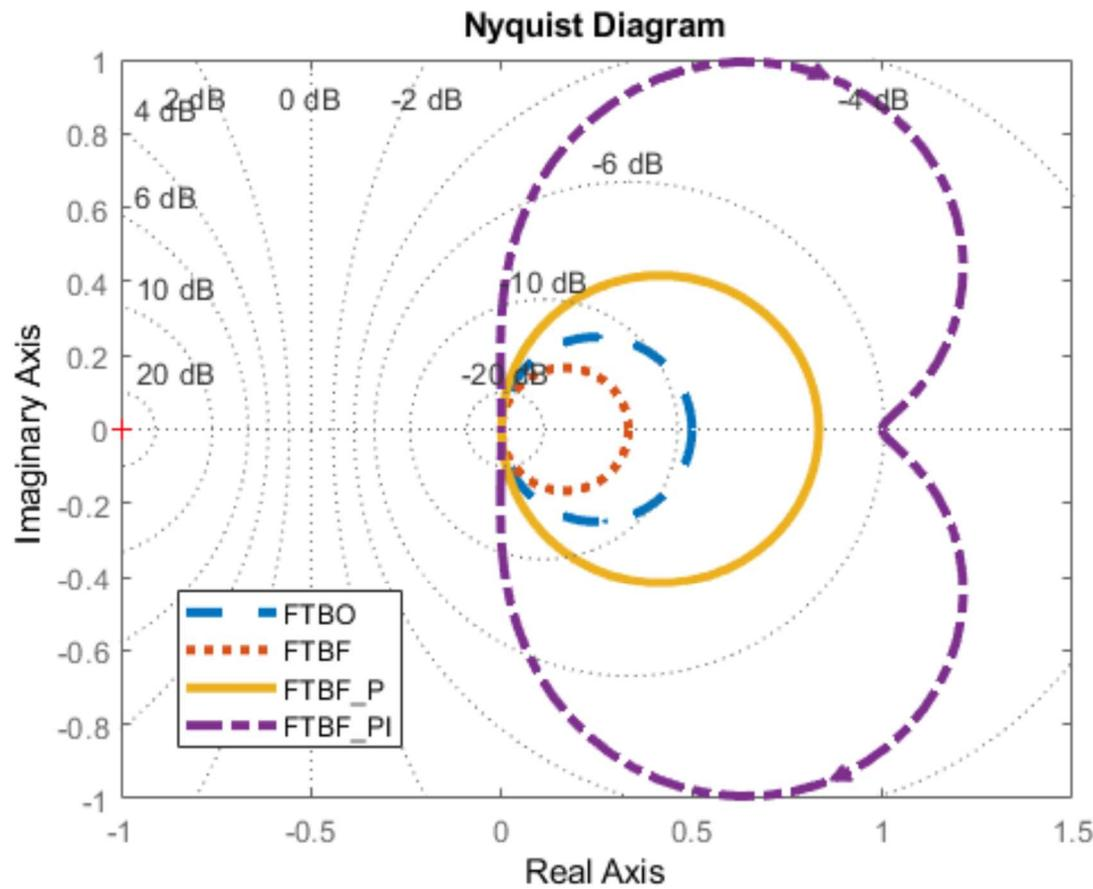

$$H(p) = \frac{H_0}{1 + \tau \cdot p}$$

$$C(p) = 1$$

$$C(p) = G$$

$$C(p) = G + 1/(\tau_i \cdot p)$$



• Exercice 1 / Correction et stabilité

$$C(p) = G + 1/(\tau_i \cdot p)$$

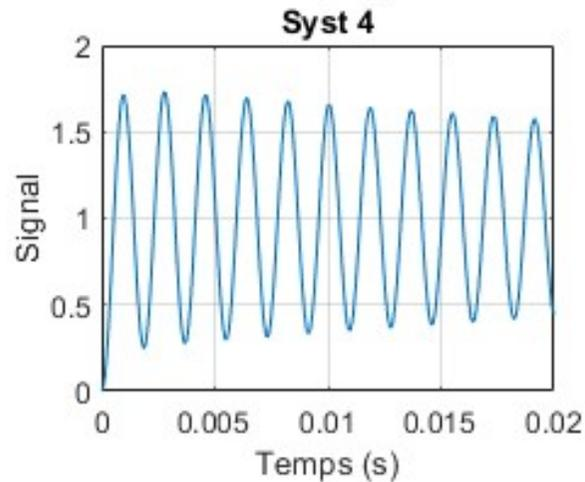
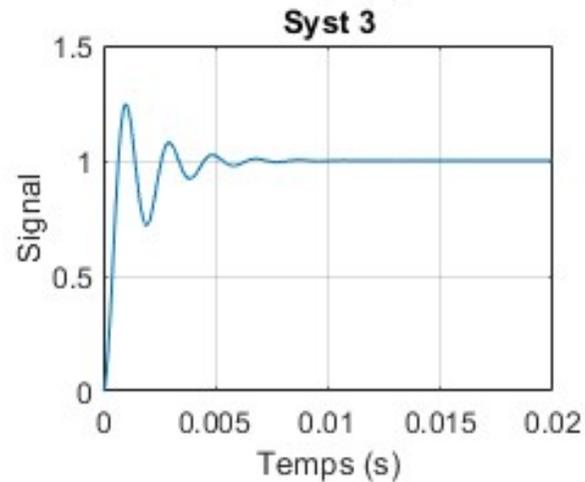
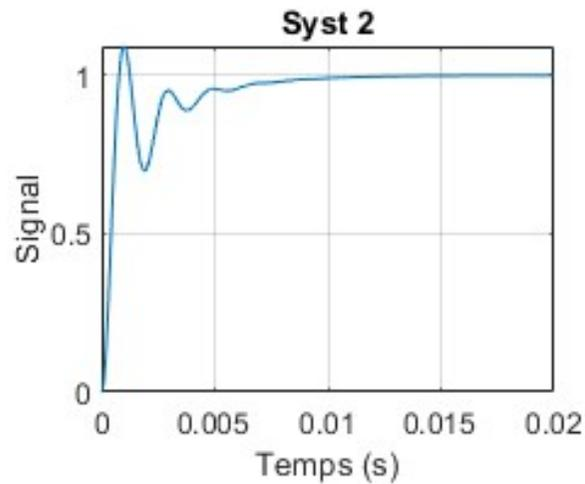
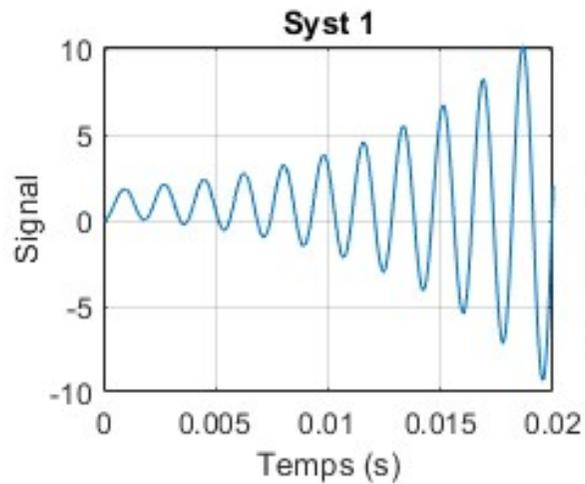

• Exercice 1 / Correction et stabilité

$$C(p) = G + 1/(\tau_i \cdot p)$$

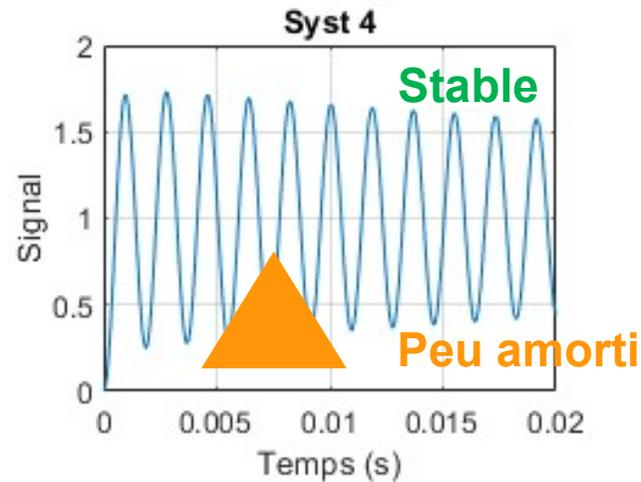
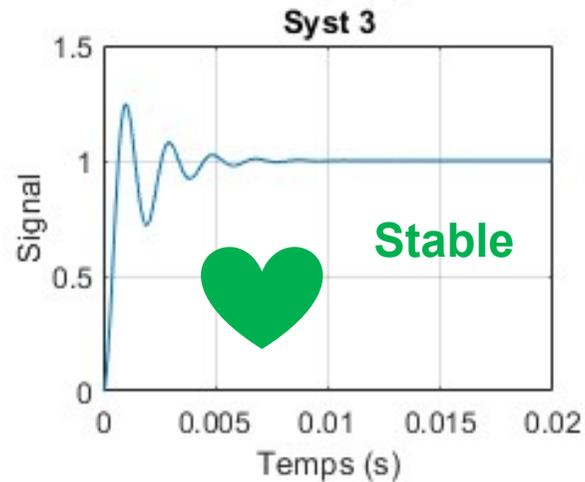
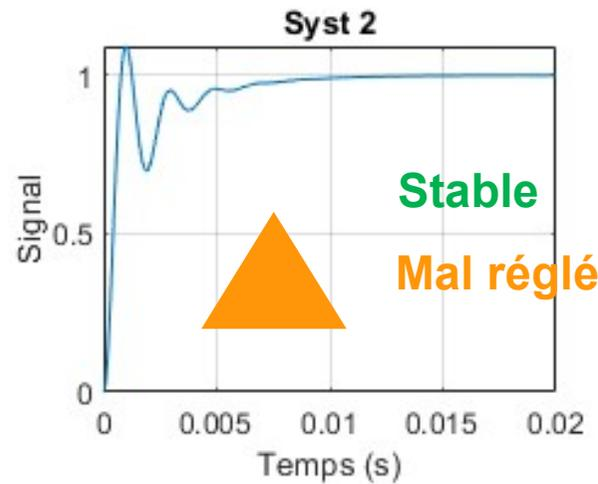
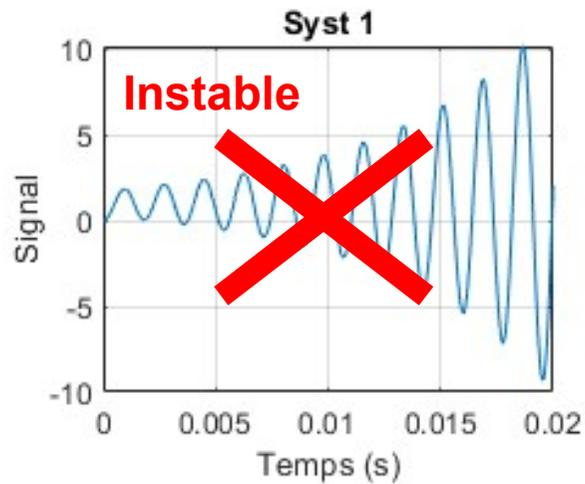

• Exercice 2 / Retour AII

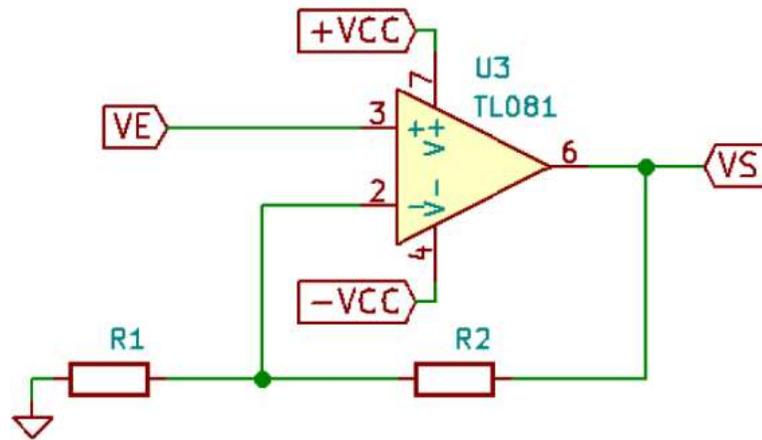

$$A(p) = \frac{V_S(p)}{\varepsilon(p)} = \frac{A_0}{1 + \frac{p}{\omega_c}}$$



• Exercice 2 / Retour ALI

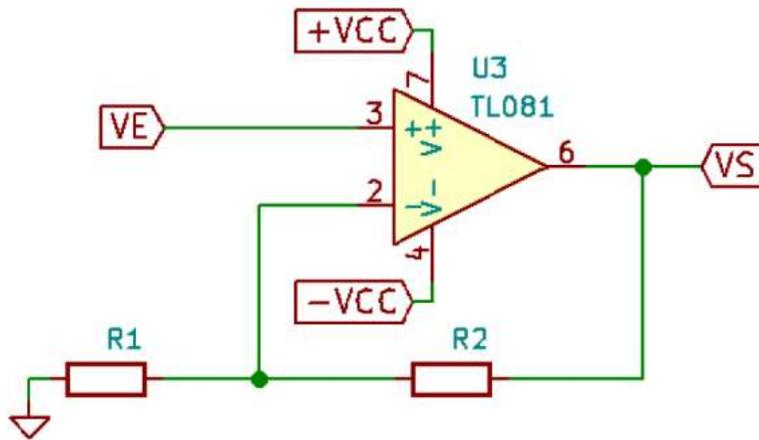

$$A(p) = \frac{V_S(p)}{\varepsilon(p)} = \frac{A_0}{1 + \frac{p}{\omega_c}}$$

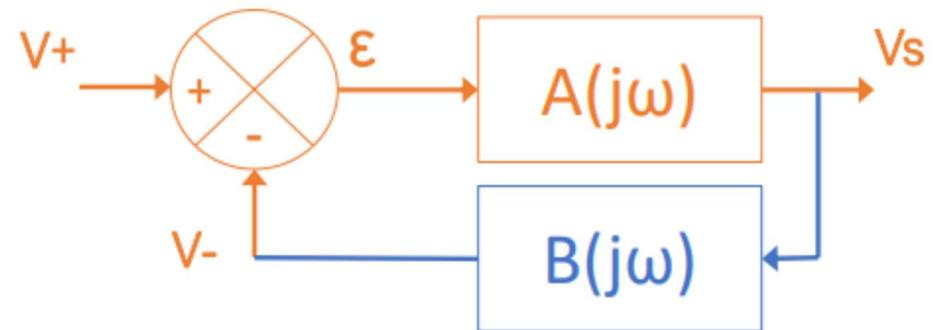

$$B(p) = V_-(p)/V_S(p) = R_1/(R_1 + R_2)$$



• Exercice 2 / Retour ALI

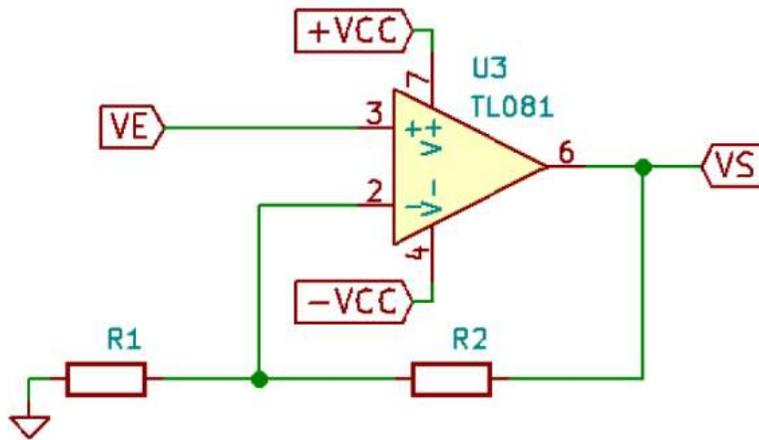

$$A(p) = \frac{V_S(p)}{\varepsilon(p)} = \frac{A_0}{1 + \frac{p}{\omega_c}}$$

$$G(p) = \frac{A_0}{1 + A_0 \cdot \frac{R_1}{R_1 + R_2}} \cdot \frac{1}{1 + \frac{p}{\omega_c} \cdot \frac{1}{1 + A_0 \cdot \frac{R_1}{R_1 + R_2}}}$$



• Exercice 2 / Retour ALI

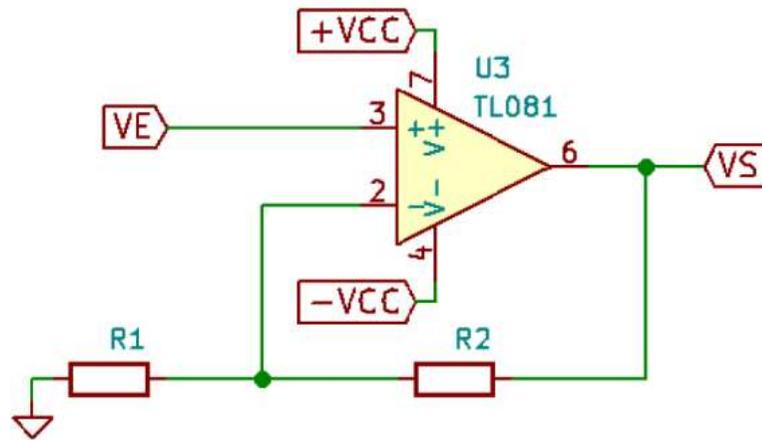

$$A(p) = \frac{V_S(p)}{\varepsilon(p)} = \frac{A_0}{1 + \frac{p}{\omega_c}}$$

$$G_0 = \frac{A_0}{1 + A_0 \cdot \frac{R_1}{R_1 + R_2}} \Rightarrow G_0 = \frac{R_1 + R_2}{R_1}$$

$$\omega_0 = \omega_c \cdot \left(1 + A_0 \cdot \frac{R_1}{R_1 + R_2}\right)$$

$$\Rightarrow f_0 = GBP \cdot \frac{R_1}{R_1 + R_2}$$

$$G(p) = \frac{A_0}{1 + A_0 \cdot \frac{R_1}{R_1 + R_2}} \cdot \frac{1}{1 + \frac{p}{\omega_c} \cdot \frac{1}{1 + A_0 \cdot \frac{R_1}{R_1 + R_2}}}$$



• Exercice 3 / Retour transimpédance

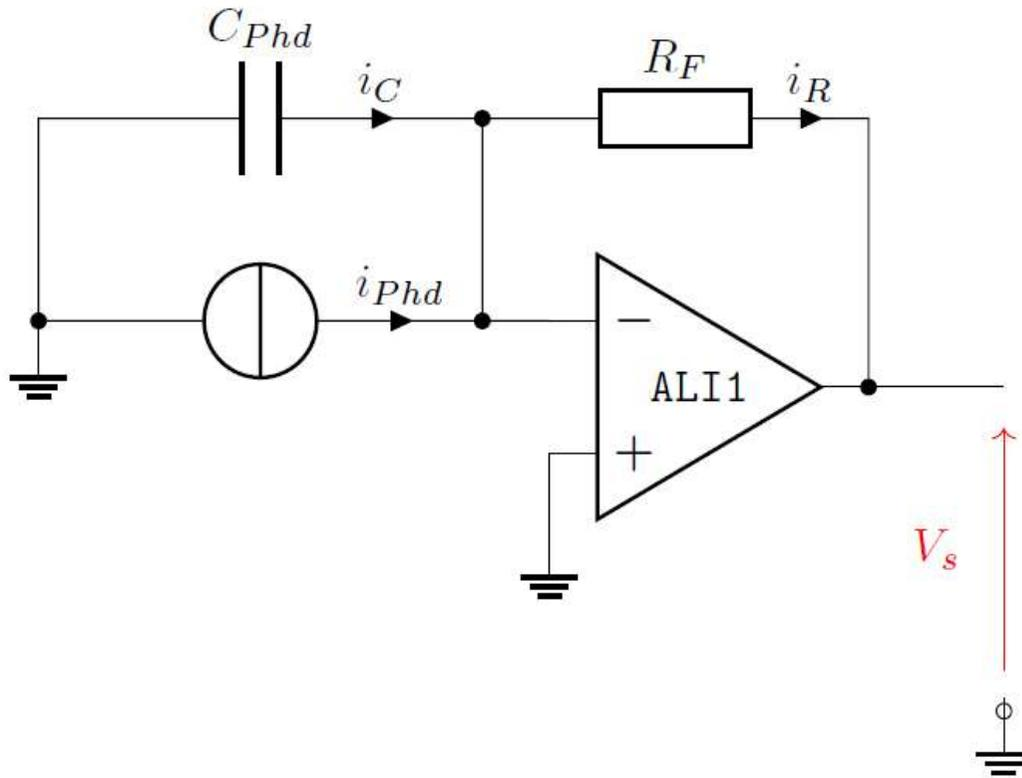

$$\omega_0 = GBP/A_0$$

$$\omega_c = \frac{1}{R_F \cdot C_{Phd}}$$

$$K = \frac{A_0}{1+A_0}$$

$$\frac{V_s}{i_{Phd}} = K \cdot \frac{R_F}{1 + p \cdot \frac{1}{1+A_0} \left(\frac{\omega_c + \omega_0}{\omega_c \cdot \omega_0} \right) + (p)^2 \cdot \frac{1}{1+A_0} \frac{1}{\omega_c \cdot \omega_0}}$$



• Exercice 3 / Retour transimpédance

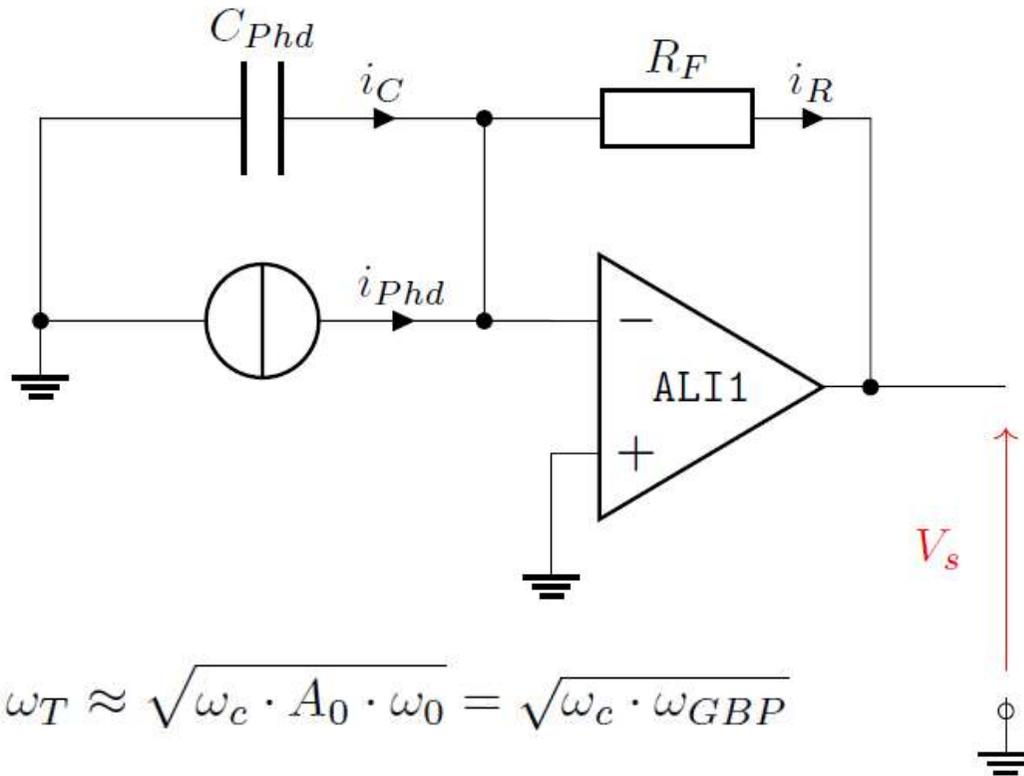

$$\omega_T \approx \sqrt{\omega_c \cdot A_0 \cdot \omega_0} = \sqrt{\omega_c \cdot \omega_{GBP}}$$

$$m_T = \frac{\omega_c + \omega_0}{2 \cdot \omega_T} \approx \frac{1}{2} \cdot \sqrt{\frac{\omega_c}{\omega_{GBP}}}$$

