

Lab work in photonics.

Detectors and noise.

1	Photodetection noise sources	1
2	Infrared detector characteristic measurement	21
3	CMOS sensor	39
4	Thermal camera	49

Rooms	B1	B2	B3	B4
	S1.20	S1.15	S1.24	S1.28

lense.institutoptique.fr | Deuxième année | Photonique S8

Engineer - 2nd year - S8 -Palaiseau
Version : January 24, 2024
Year 2023-2024

B 1

Photodetection noise sources

Version: January 24, 2024

Prepare the question P1 before the session.

Contents

1	Objectives	1
2	Measuring noise	2
3	Amplification noise	5
4	Thermal resistance noise	8
5	Photon noise	10
6	Noise reduction	13
7	Short guidelines for the redaction of the report	16
	Appendix 1. Bode diagrams of the amplifiers	18
	Appendix 2. The spectrum analyser	19

1 Objectives

At the end of this lab session, you are expected to be able to:

- differentiate between an offset (typically a dark current) and a noise;
- measure a noise amplitude, *i.e.* to be able to:
 - use an electrical spectrum analyzer;
 - convert quantities expressed in $\text{dBm}_{@1\text{Hz}}$ and in W/Hz ,
 - explain how the Spectrum Analyzer (SA) performs a measurement;

- determine the influence of important parameters in any noise measurement, and in particular, the influence of the bandwidth (ENBW);
- evaluate the uncertainty of the measurement;
- break down the different contributions (amplification noise, thermal noise, photon noise) to the total noise;
- propose a measurement method for each kind of noise;
- verify if a detection system is limited by photon noise;
- justify the term “photon noise”.

The objective of the first three parts of this lab is to study the main sources of noise present in any optical sensing system: the amplification noise, the thermal noise, and especially the photon noise.

The photon noise is related to the quantum nature of light. It has long been considered as a fundamental limitation. Under certain very particular conditions, it is nevertheless possible to fall below the photon noise limit, also known as the “standard quantum limit”, as has been demonstrated for the first time in 1985¹. The last part presents an experiment that reduces the photon noise to a value below the standard quantum limit.

You are asked to fill up a table during the lab in order to record your measurements and verify their validity.

2 Measuring noise

2.1 Statistical approach

A noise is a random process. When measuring a noise, we want to determine its statistical properties, in particular its variance, also known as its rms value. By definition :

$$V_{rms}^2 = \int v^2 p(v) dv$$

where $p(v)$ is the density of probability of the process. It is not always known, but it can be estimated, experimentally measured.

¹Slusher *et al.*, Phys. Rev. Lett. **55**, 2409 (1985).

2.2 Time-domain measurement

For all stationary and ergodic stochastic signals, we consider that the temporal statistical properties are the same as the ensemble statistical properties. This is the case for all kind of noise we will study here.

Therefore, with an oscilloscope, one can measure the Root Mean Square voltage V_{rms} of $v(t)$ (mean value is zero) defined by:

$$V_{\text{rms}}^2 = \lim_{T \rightarrow +\infty} \frac{1}{T} \int_{[T]} v^2(t) dt$$

This is the definition of the total power of a signal. This is also the temporal standard deviation for a noise:

$$V_{\text{rms}}^2 = \sigma_v^2 = \langle v^2(t) \rangle \quad \forall t$$

2.3 Frequency-domain measurement

The same RMS voltage measurement can be done in the frequency domain. With a spectrum analyzer (SA), we can measure the **Power Spectral Density** (PSD) of an electric signal. The PSD is defined by:

$$\text{PSD}(f) = \frac{1}{R_{\text{SA}}} \lim_{T \rightarrow +\infty} \frac{2}{T} \langle |\widetilde{v}_T(f)|^2 \rangle \quad (1.1)$$

for frequencies $f > 0$. v_T is the signal $v(t)$, limited to the interval $[0 T]$, $\widetilde{v}_T(f)$ is its Fourier Transform. R_{SA} is the input resistance of the SA. The PSD is expressed in W/Hz.

The rms noise voltage, normalized at 1 Hz, v_n (n for *noise*), is:

$$v_n(f) = \sqrt{R_{\text{SA}} \cdot \text{PSD}(f)} \text{ in } \text{V}/\sqrt{\text{Hz}}.$$

We get the total power, so the RMS voltage by integrating the PSD over all frequencies :

$$V_{\text{eff}}^2 = R_{\text{SA}} \int_0^{+\infty} \text{DSP}(f) df = \int_0^{+\infty} v_n^2(f) df$$

2.4 Link between the autocorrelation function of a noise and the PSD

Thanks to the Parseval theorem, we know that the total power of a signal does not depend on the representation (time or frequency) of the signal. There is a connection between those two, given by the Wiener-Khintchine theorem. The

PSD can be obtained from the autocorrelation function $c_v(\tau) = \langle v(t)v(t-\tau) \rangle$ by a Fourier Transform :

$$\frac{2}{R_{SA}}c_v(\tau) \xrightarrow{\text{FT}} \text{PSD}(f)$$

And for $\tau = 0$, thus leads to:

$$V_{\text{eff}}^2 = \sigma_v^2 = c_v(0) = R_{SA} \int_0^{+\infty} \text{DSP}(f)df$$

2.5 White noise. Filtering.

The noises studied in this lab are very chaotic signals. There is no correlation between their value at time t and at time $t + \tau$. Their autocorrelation function, $c_v(\tau)$, is zero for all the values of τ except 0: $c_v(\tau) = 0$ except in $\tau = 0$. The PSD is then constant for all frequencies. By analogy with optics, the expression of "white noise" is used to characterize them. A white noise is a mathematical model. Its variance is infinite. We usually talk about white noise in a given bandwidth if the PSD is constant in this frequency bandwidth.

Furthermore, the measurement of a noise is always limited by a given bandwidth which can be the scope bandwidth, the resolution bandwidth of the spectrum analyzer, the bandwidth of a filter, The measured rms voltage is then :

$$V_{\text{eff}}^2 = \int_0^{\Delta f} v_n^2(f) df = v_n^2(f) \Delta f$$

where $v_n(f)$ is the rms noise voltage normalized at 1 Hz, and is supposed to be constant in the bandwidth of analysis Δf .

So, measuring a noise consists in giving its rms voltage normalized at 1 Hz AND the bandwidth in which this power is measured !

Be aware that two noises may have the same PSD and very different time traces. An example of this is given on the figure 1.1 :

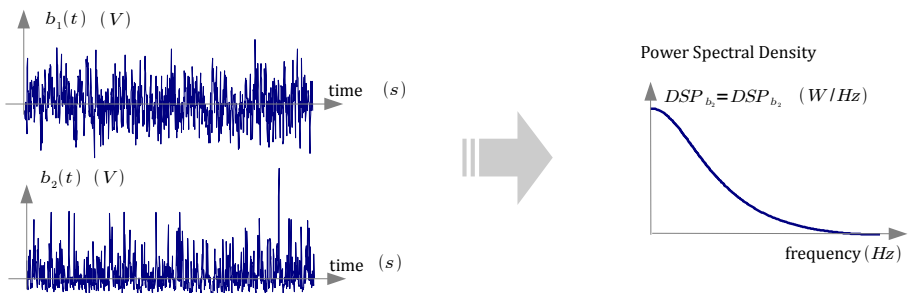

Figure 1.1: Two different noises with the same PSD.

P1 What is the shape of these two noise histograms? Are their autocorrelation functions identical? Which one is a white noise? Which one is a Gaussian noise?

3 Amplification noise

We need a low-noise and high gain amplifier to measure the thermal noise of a resistance or the photon noise.

However, the amplifier produces its own noise. The aim of this part is to measure the amplifier noise.

This amplifier noise is the output noise of the complete electronic system, added to an amplified signal. Its rms value is noted $V_{\text{ampli,out}}$. In order to compare amplifiers with different gain and bandwidth values, the input rms noise voltage normalized at 1 Hz, is given. We consider then a noise generator at the input of an amplifier as shown in figure 1.2. We have to measure the rms noise voltage $v_{\text{n,ampli}}$ (in $\text{V}/\sqrt{\text{Hz}}$) of this white noise.

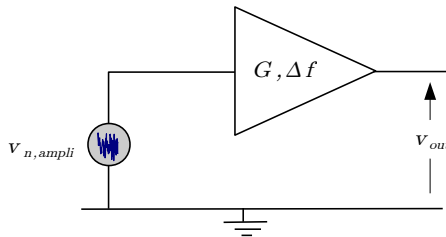

Figure 1.2: Input white noise model. G is the amplifier gain and Δf is its bandwidth

The circuit diagram we will use is drawn on the figure 1.3: It corresponds to « Ampli 1 » aluminium box, with a grounded input. To shortcut the entrance, use the box of resistances connected directly to the Ampli 1 box input, and choose the $R = 0\ \Omega$ position. The amplifier is powered by batteries ($\pm 12\ \text{V}$) to avoid additional noise.

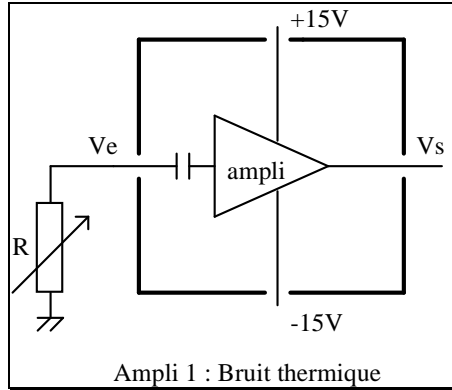

Figure 1.3: Amplifier noise and thermal noise measurements circuit.

3.1 Noise measurement with an oscilloscope.

↪ Observe the output signal with the oscilloscope (1 or 2 mV/division).

Q1 Observe the output voltage when you change the time scale. Does the shape of the noise seem compatible with a Gaussian white noise?

Q2 Measure approximately $V_{\text{peak to peak}}$ of the noise observed on the oscilloscope. Assuming this noise is a Gaussian noise, we know that : $V_{\text{peak to peak}} \approx 6V_{\text{RMS}}$.

Deduce the Root Mean Square (RMS) value ($V_{\text{ampli, out}}$) of the amplifier output voltage.

Furthermore we suppose that the amplifier gain is 300 and constant over a bandwidth of $\Delta f = 1,5 \text{ MHz}$ (Bode Diagram in appendix)

Q3 What is the relationship between $v_{n, \text{ampli}}$ and $V_{\text{ampli, out}}$? Deduce from your measurement the rms input voltage noise of the amplifier $v_{n, \text{ampli}}$ and compare to the AH0013 datasheet typical value: $v_{n, \text{AH1003}} = 2 \text{ nV}/\sqrt{\text{Hz}}$

3.2 Noise measurement with a spectrum analyzer

With a spectrum analyzer (Tektronix 2712 for example), one can measure the PSD of the noise (scheme in appendix).

The SA displays the electric power of its input voltage in W or in dBm signal, dissipated in its input resistance $R_{\text{SA}} = 50 \Omega$.

If this signal is a sine wave at frequency f_0 $v(t) = \sqrt{2}V_{\text{rms}} \sin(2\pi f_0 t + \phi)$, the displayed power is $P(f_0) = \frac{V_{\text{rms}}^2}{R_{\text{SA}}}$.

If this signal is periodic, the SA displays the power of each spectral component of the signal

If this signal is a noise, the SA displays the signal PSD, integrated over the resolution bandwidth $\delta f = \text{RBW}$ around f_0 :

$$P(f_0) = \frac{1}{R_{\text{SA}}} \int_{f_0 - \frac{\delta f}{2}}^{f_0 + \frac{\delta f}{2}} v_n^2(f) \cdot df \quad (\text{in W})$$

If we assume that the PSD is constant over δf :

$$P(f_0) = \frac{1}{R_{\text{SA}}} \cdot v_n^2(f_0) \cdot \delta f \quad (\text{in W})$$

Dividing this value by the resolution bandwidth, the SA measures the PSD (in W/Hz) of the electrical signal :

$$\text{PSD}(f_0) = P_{\text{@1 Hz}}(f_0) = \frac{v_n^2(f_0)}{R_{\text{SA}}} \quad (\text{in W/Hz})$$

Reminder: Remember that dBm is a logarithmic power unity. 'm' means that the reference is 1 mW. A power in dBm is given by: $P_{\text{dBm}} = 10 \log_{10} \left(\frac{P}{1 \text{ mW}} \right)$ where P is expressed in mW. So, 0dBm is 1 mW, -30dBm is 1 μ W, -60dBm is 1 nW, etc.

A PSD is given in dBm_{@1 Hz}: $P_{\text{@1 Hz, dBm}} = 10 \log \left(\frac{P_{\text{@1 Hz}}}{1 \text{ mW}} \right)$

↔ Connect the output of the amplifier to the spectrum analyzer input. Measure $P_{\text{@1 Hz}}$ (300 kHz) in dBm, the amplifier noise output power spectral density at 300 kHz.

Q4 Using Excel, calculate the corresponding noise voltage, $v_{n,\text{out}}(300 \text{ kHz})$, at the amplifier output expressed in $V/\sqrt{\text{Hz}}$. The SA input resistance is $R_{\text{SA}} = 50 \Omega$.

Q5 Determine the value of the amplifier gain at a frequency of 300 kHz from the Bode diagram of the amplifier given in Appendix. Deduce the rms input noise voltage $v_{n,\text{ampli}}$. Compare it to the value obtained in the previous section and to the datasheet value for the low noise amplifier AH0013: $v_{n,\text{AH1003}} = 2 \text{ nV}/\sqrt{\text{Hz}}$.

Q6 Observe the output noise voltage of the amplifier for a larger span of frequencies from 0 to 2 MHz. Is it a white noise? Why? Compare to the Bode diagram (ampli Johnson noise) given in appendix. Explain why we can measure the Bode diagram of the amplifier by this method.

↪ Check your calculations and your measurements with lab instructor.

4 Thermal resistance noise

With this amplifier it is easy to study the thermal noise (Johnson noise) of a resistance.

Voltage fluctuations across a resistor R at the absolute temperature T is a Gaussian white noise called thermal noise or Johnson noise. The rms noise voltage is given by the Johnson-Nyquist formula:

$$v_{n,R} = \sqrt{4kTR} \text{ in } V/\sqrt{\text{Hz}},$$

where k is the Boltzmann constant: $k = 1.380 \times 10^{-23} \text{ J} \cdot \text{K}^{-1}$

A resistance can be replaced by a noiseless resistance R^* with a noise voltage generator of rms value $v_{n,R}$ as represented in the figure 1.4.

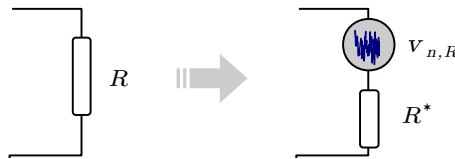

Figure 1.4: Resistance thermal noise model

The low noise amplifier studied previously can be used to study the thermal noise of a resistor connected between the amplifier input and ground.

4.1 Influence of the resistance

↪ With the spectrum analyzer, measure $P_{@1 \text{ Hz}}(300 \text{ kHz})$ in dBm (output noise PSD at the frequency of 300 kHz) for different resistors connected to the amplifier input.

Q7 Deduce the amplifier rms voltage output noise, $v_{n,\text{out}}(300 \text{ kHz})$, for these resistances (fill up the table started at question **Q4**).

At the entrance of the amplifier, we have two sources of noise,

- the amplifier noise, measured at question **Q5**,

- the resistance thermal noise.

We can represent these two noises by two white noise generators placed at the input of the amplifier (figure 1.5).

These sources are statistically independent. Therefore, the total noise power is the sum of the powers of these two noise generators.

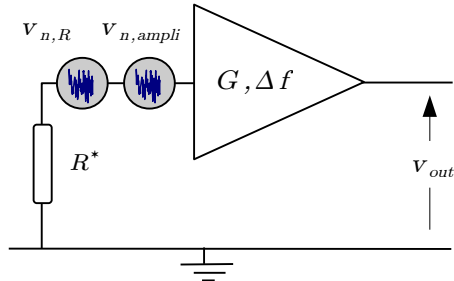

Figure 1.5: Model of the thermal noise of a resistance, at the input of a noisy amplifier.

Q8 With Excel, deduce from the previous measurements the rms noise voltage normalized at 1 Hz, $v_{n,R}$ of the thermal noise for each resistance. Do not forget to take into account the noise of the amplifier.

Q9 Trace on the same graph the curves $v_{n,R} = f(\sqrt{R})$ deduced from your measurements and from calculation using the Johnson-Nyquist formula.

Q10 Observe the noise voltage output of the amplifier for a larger frequency span from 0 to 2 MHz when you increase the value of R . Can you explain what you see? Deduce why the measured noise is different from the theoretical noise for the high resistance values.

Q11 Comparing the theoretical and experimental slopes for the small values of resistance, evaluate the systematic error measurement in dBm/Hz probably due to a calibration default of the spectrum analyzer.

Important To take into account and therefore correct this error later in the lab, keep the same settings of the spectrum analyzer.

4.2 Influence of the temperature

To measure the influence of the temperature, you will put a resistance (protected in a box) in liquid nitrogen and thus compare the noise at room temperature and at liquid nitrogen temperature. This simple experiment shows the principle of a noise thermometer by measuring the thermodynamic temperature.

↪ Connect the resistance protected by a small metal box to the amplifier input.

Q12 Measure, using the spectrum analyzer, $P_{@1\text{ Hz}}$ (300 kHz) in dBm, PSD of the output noise at a frequency of 300 kHz, when the resistance is at room temperature. Deduce the rms noise voltage normalized at 1 Hz, v_{n,R,T_1} . Do not forget to take into account the noise of the amplifier.

Q13 Repeat this measurement when the resistance is placed in liquid nitrogen. Deduce the rms noise voltage v_{n,R,T_2} at this temperature. Use this measurement to deduce the temperature of liquid nitrogen as accurately as possible.

5 Photon noise

The photon noise is related to the statistical fluctuations of the photons collected by the photodetector. The photon counting statistics is known to be Poissonian: if the detector surface receives N photons in average during an integration time τ , the standard deviation of the number of photons received is \sqrt{N} .

The photoelectrons created in the detector obey the same Poissonian statistics and this explains the shot-noise (often called photon noise) on the photocurrent. The average photocurrent is I_{ph} and the variance $i_{n,\text{ph}}^2$ of the fluctuations is given by the Schottky formula:

$$i_{n,\text{ph}} = \sqrt{2eI_{\text{ph}}} \text{ (in A}/\sqrt{\text{Hz}}) \text{ where } e \text{ is the electron charge } e = 1.6 \times 10^{-19} \text{ C}$$

A photodiode (detecting a Poissonian flux of photons) can be represented by a DC current generator I_{ph} , in parallel with a current noise generator:

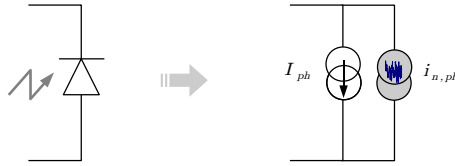

Figure 1.6: Photodetection noise model.

This current noise will be amplified by the circuit of the figure 1.7 :

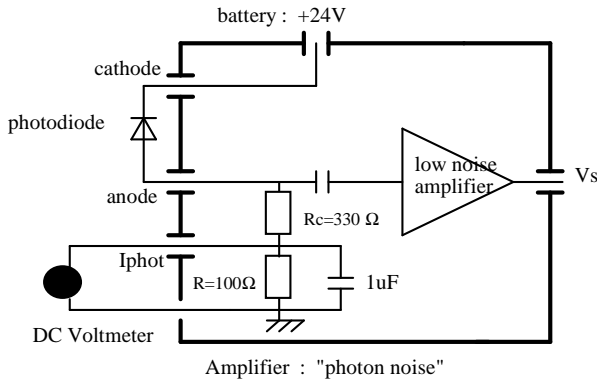

Figure 1.7: Amplifier : "photon noise"

The DC component of the current I_{ph} passes through the two resistances R_1 and R_2 . We can deduce its value from the measurement of the voltage V across R_2 ($100\ \Omega$): $I_{ph} = V/R_2$. The photodiode is reverse biased with 24 V DC supplied by a battery (noiseless).

↪ Connect the photodiode and the battery. Place the photodiode in front of a white light source which intensity is adjustable. The photodiode is an E.G.G. C30809 photodiode whose quantum efficiency is 0.83 at 900 nm (datasheet in appendix).

A voltmeter connected to the output I_{phot} of the box measures the DC photonic current delivered by the photodiode.

↪ Check the average photocurrent increases with the flux received by the photodiode (do not go above 10 mA, 1 V on the voltmeter).

↪ Observe the noise output voltage of the amplifier using the oscilloscope and the spectrum analyzer when increasing the flux.

Q14 Observe the output noise for a span from 0 to 2 MHz. Is the shot noise a white noise? How is it varying with the flux received by the photodiode?

Q15 Measure, using the spectrum analyzer, $P_{@1\text{ Hz}}$ (300 kHz) in dBm, PSD of the output noise at a frequency of 300 kHz, for different average photocurrents I_{ph} from 0 to 10 mA. Deduce the rms noise voltage $v_{n,\text{out}}(300\text{ kHz})$ for these values of I_{ph} .

At the entrance of the amplifier, we have now three sources of noise:

- the photon noise $v_{n,\text{ph}} = R_1 \cdot i_{n,\text{ph}}$,
- the resistance ($R_1 = 324\ \Omega$) thermal noise, v_{n,R_1} ,
- and the amplifier noise, $v_{n,\text{ampli}}$.

Note that the R_2 resistance is not taken into account here because it is short-circuited by the capacitor in parallel. The complete noise model of the photodetection is given by the circuit in Figure 1.8:

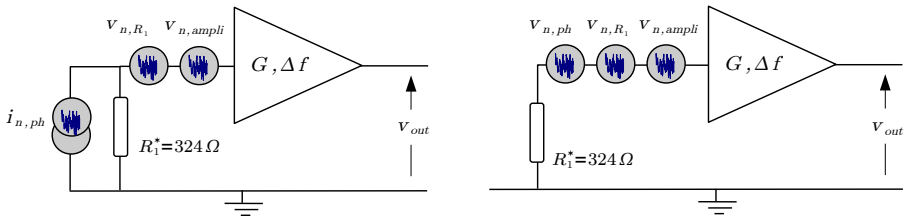

Figure 1.8: Photodetection noise model.

These noise sources are statistically independent. So their noise powers can be summed in order to find the total noise power:

$$v_{n,\text{tot}}^2 = v_{n,R_1}^2 + (R_1 \cdot i_{n,\text{ph}})^2 + v_{n,\text{ampli}}^2 \quad (v_{n,\text{tot}} \text{ in } V/\sqrt{\text{Hz}})$$

The noise measurement when $I_{\text{ph}} = 0\text{ mA}$ gives the measurement of the amplifier and thermal noises.

Q16 Determine the value of the amplifier gain at a frequency of 300 kHz from the Bode diagram of the amplifier given in Appendix, deduce the voltage noise at the input of the amplifier: $v_{n,\text{tot}}$.

Q17 With Excel, calculate the rms noise current $i_{n,\text{ph}}$ taking into account the systematic error determined in question **Q11**.

Q18 Plot: $i_{n,ph} = f(\sqrt{I_{ph}})$. Compare with the values given by the Shottky formula.

↪ Check your calculations and your measurements with the lab instructor.

6 Noise reduction

This last part presents a way to measure a photocurrent with a noise power below the shot-noise limit. This experiment will prove that the photodetector is not responsible for the shot-noise. Shot-noise is related to the quantum nature of light and the shot-noise limit is due to the Poissonian statistics of the collected photons. This experiment will show that a suitable light source can give a sub-Poissonian statistics of photons collected and consequently leads to a reduction of noise.

The idea is here to use, as a light source, a high quantum efficiency light-emitting diode (Hamamatsu L2656 whose quantum efficiency is about 0.15 photons per electron at center wavelength of 890 nm). We put this LED as close as possible to the photodiode (E.G.G. C30809) to collect the largest number of photons we can (we took off the window of the photodiode, and both the LED and the photodiode are in a metal box).

The figure below explains the principle of the shot-noise reduction experiment:

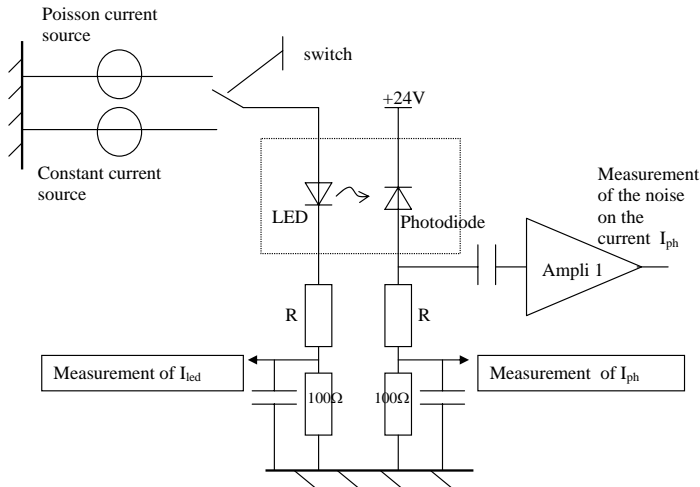

Figure 1.9: Principle of the shot-noise reduction experiment

Figure 1.10 represents the circuit which drives the LED either with a very

low noise current produced by an usual stabilized power supply (KIKUSUI) or with a “Poissonian” current produced by three photodiodes illuminated by an ordinary white light source. Changing the light level will change the mean current through the LED. It is easy to adjust the stabilized power supply and the light level in a way to get exactly the same mean current in the LED. This current, I_{LED} , is measured by a voltmeter in parallel with the $300\ \Omega$ resistance.

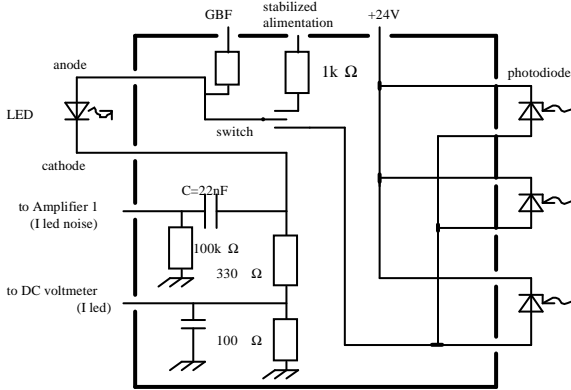

Figure 1.10: Setup of the sub-Poissonian/Poissonian light emitting device

6.1 Connecting the circuit

↪ Replace the photodiode of the previous part by the photodiode which is in the small box “photodiode + LED”.

↪ Connect a second voltmeter at the I_{LED} output to measure the average current in the LED. Connect the stabilized power supply and the bias voltage polarization for the 3 photodiodes (24 V) to the commutation box. Do not connect anything to the input “GBF”.

↪ Put the switch on the “stabilized power supply” position and adjust the photocurrent in the photodiode at exactly 3 mA.

↪ Put the switch on the “Poisson current” position, and adjust the flux on the 3 photodiodes in order to get the exactly same photocurrent (3 mA) in the photodiode.

6.2 Measurement

Q19 Measure the current in the LED and deduce the total quantum efficiency η_T , *i.e.* the number of electrons delivered by the photodiode per second divided by the number of electrons crossing the LED per second.

Q20 With the spectrum analyzer, measure $P_{@1\text{ Hz}}$ (300 kHz) in dBm. Check that you find exactly the same value as in the previous part (**Q15**). This proves you are at the shot noise level.

Q21 Deduce the rms noise current $i_{n,\text{ph}}$.

↔ Switch to the “stabilized power supply” position. Check that the DC current is still $I_{\text{ph}} = 3\text{ mA}$.

Q22 Measure $P_{@1\text{ Hz}}$ (300 kHz) in dBm. Deduce the rms noise current $i_{n,\text{ph}}$.

Q23 What noise reduction (in dB) do you find?

Q24 Compare to the value calculated as explained in the next paragraph.

To obtain a better visualization of the noise reduction, you can display the spectrum on 5dB/div scale. Then you can average the spectrum on the “Poissonian current” position and save it. At last, average the spectrum on “stabilized power supply” position and save it.

↔ Ask the lab instructor how to use the average function of the spectrum analyzer.

6.3 Simple explanation of the noise reduction

When a constant current source is used to drive the LED, the noise on the current is very low. The fluctuations of the number of electrons crossing the LED are very low in comparison with a “Poissonian statistics”. If the quantum-efficiency of the LED was equal to one, the fluctuations of the number of photons emitted by the LED and collected by the photodiode would be very low too. The resulting noise reduction would be very large.

Unfortunately, the total quantum efficiency, $\eta_T = \eta_{\text{phD}} \cdot \eta_{\text{LED}}$, is only about 0.17. This means that for six electrons crossing the LED only one electron on average will be generated by the photodiode.

If we suppose that the current in the LED is noiseless, the number of electrons through the LED, $N_{e,\text{LED}}$, during a time τ , is constant. The number of electrons generated by the photodiode during a time τ is thus given by a binomial distribution. The mean value and the variance of the number of electrons crossing the photodiode during a time τ are:

$$\overline{N_{e,\text{photodiode}}} = \eta_T N_{e,\text{LED}}$$

and:

$$\sigma_{N_{e,\text{photodiode}}} = \sqrt{\eta_T (1 - \eta_T) N_{e,\text{LED}}}$$

This leads to:

$$I_{\text{ph}} = \frac{\overline{N_{e,\text{photodiode}}}}{\tau} e = \eta_T \frac{\overline{N_{e,\text{LED}}}}{\tau} e = \eta_T I_{\text{LED}},$$

and the rms value $i_{\text{rms,ph}}$ of this photocurrent:

$$i_{\text{rms,ph}} = \frac{\sigma_{N_{e,\text{photodiode}}}}{\tau} e = \sqrt{\eta_T (1 - \eta_T) N_{e,\text{LED}} \frac{e^2}{\tau^2}}$$

The bandwidth is $\delta f = 1/2\tau$, so the photocurrent noise is:

$$i_{\text{rms,ph}} = \sqrt{2eI_{\text{ph}} (1 - \eta_T) \delta f} \text{ (in A)}$$

instead of

$$i_{\text{rms,ph}} = \sqrt{2eI_{\text{ph}} \delta f}$$

for the shot noise. Thus, the noise power reduction is:

$$\frac{P_{\text{reduced}}}{P_{\text{photon}}} = 1 - \eta_T$$

In dB:

$$P_{\text{reduction,dB}} = P_{\text{reduced,dBm}} - P_{\text{photon,dBm}} = 10 \log (1 - \eta_T)$$

7 Short guidelines for the redaction of the report

For the report, please do not answer all the questions of the text linearly and do not describe all your experimental procedures. Please explain for all three configurations what are the contributions to the noise, their nature and their rms levels. A particular attention will be paid to the graphs in Parts "Thermal resistance noise" (influence of the resistance) and "Photon noise". Thus, We expect you to establish a brief overview of the noise levels in the different setups under study. Redaction of the last part "Noise reduction" is optional, but will be strongly taken into consideration if satisfying.

References on noise reduction

- [1] Introduction à la réduction du bruit quantique. S. Reynaud
Ann. Phys. Fr. 15, 63 (1990).
- [2] Sub-Shot-Noise Manipulation of Light Using Semiconductor Emitters and
Receivers. J.-F. Roch, J.-Ph. Poizat and P. Grangier
Physical Review Letters Vol 71, Number 13 (1993)

Appendix 1. Bode diagrams of the amplifiers

Amplifier 1 - Thermal resistance noise

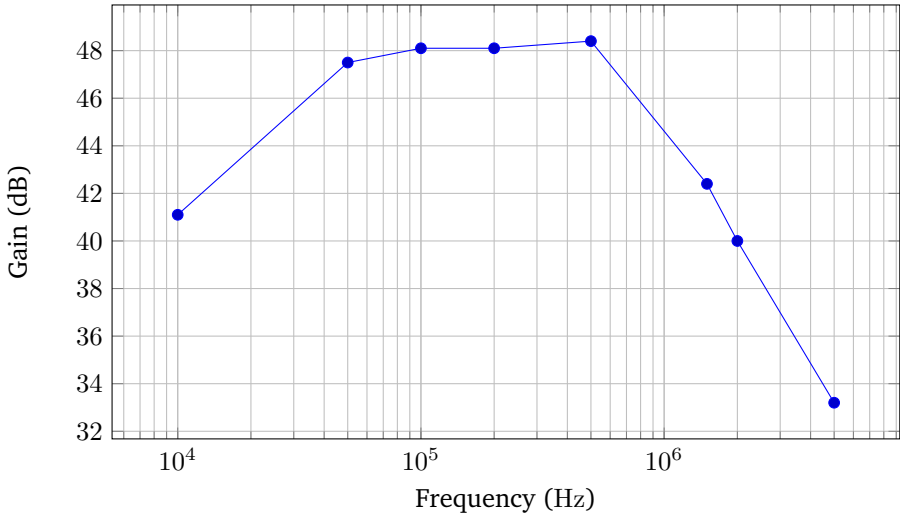

Amplificateur 2 - Photon noise

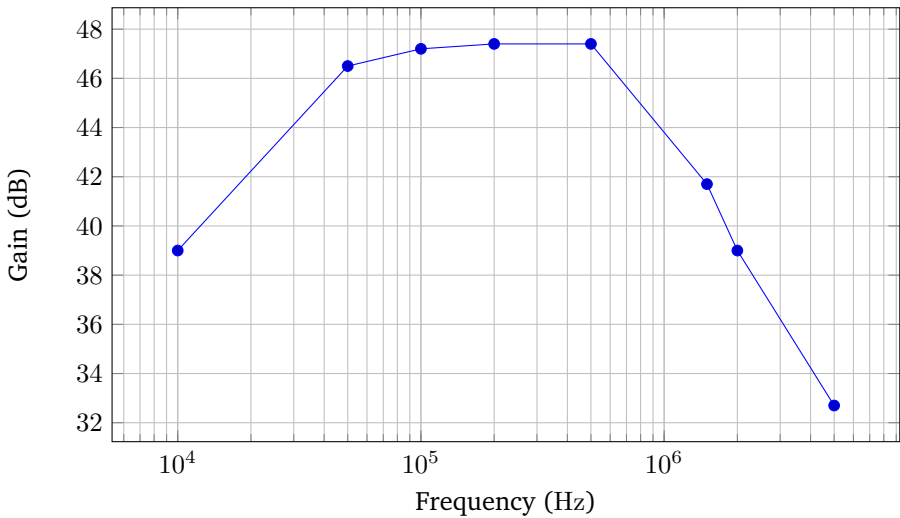

Appendix 2. The spectrum analyser

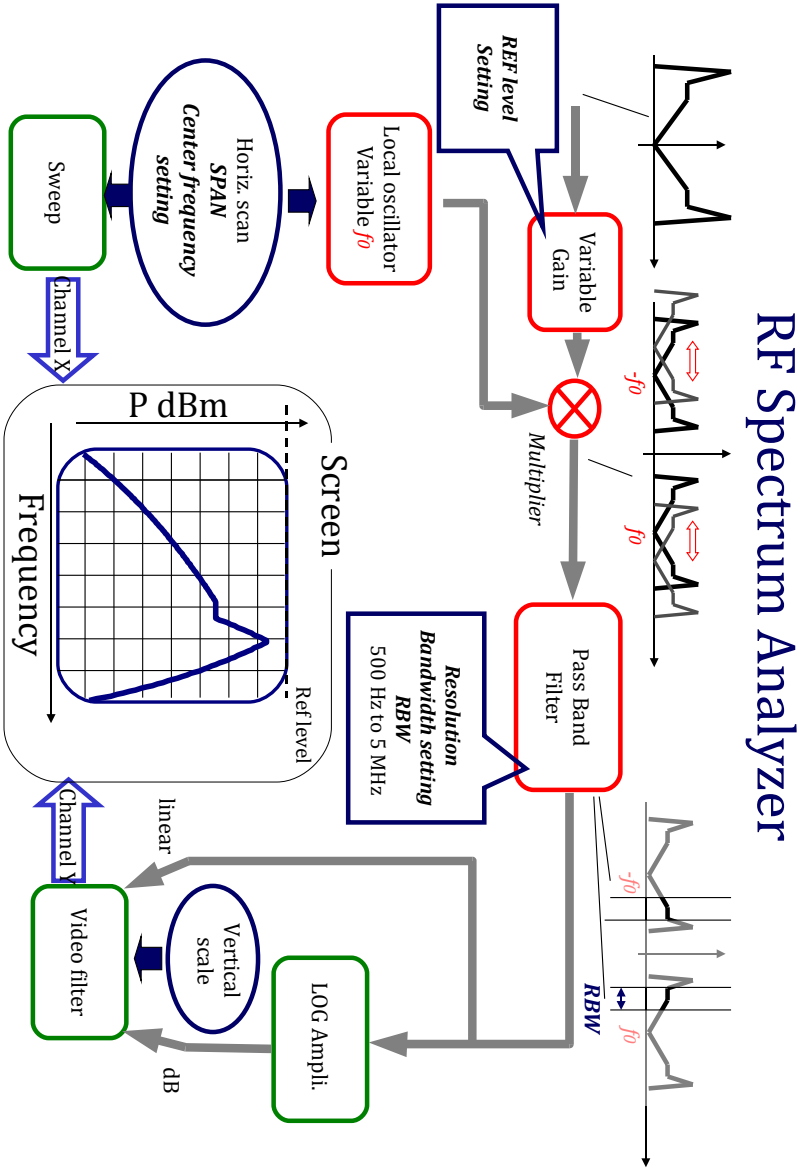

B 2

Infrared detector characteristic measurement

Version: January 24, 2024

You should read carefully this text and prepare the questions P1-P12 before the lab.
Data analysis have to be done and checked during the lab session.

Contents

1	Objectives	21
2	Detector characteristics	22
3	Measurements	26
4	Analysis of the measurements	33
5	Writing down the report	34
	Appendix 1 - Black body spectral radiance	36
	Appendix 2 - Atmospheric transmittance	36
	Appendix 3 - Spectral detectivity	37

1 Objectives

At the end of the session lab, you will be able to:

- measure the performance of an infrared detector, which means being able to:

- identify the relevant parameters (dark current, quantum efficiency, black-body response, noise, detectivity);
 - identify the specificities of the IR domain (black-body radiation, ambient background, dark current of the detector);
 - use a digital spectrum analyzer and understand the need for an anti-aliasing filter and an appropriate window;
 - understand the rationale behind the use of a chopper;
 - be able to compute the étendue of the measurement setup;
 - evaluate the uncertainty of each measurement;
- propose a measurement procedure that can be used to verify if an IR detector is limited by the background photon noise (BLIP).

During this lab, we will therefore measure the characteristics of an IR detector cooled to 77 K by liquid nitrogen.

The detector is an **InSb** photodiode (**sensitive in the 3–5 microns spectral band**), with model reference P5968–100 Hamamatsu. The diameter is 1 mm and the total angle of view is 60°.

The full characteristics of the detector can be found online:

<http://jp.hamamatsu.com>

This lab will provide an opportunity to apply concepts learnt in the course of photometry and detectors noise, and to familiarize with conventional experimental techniques. Measurements are relatively simple and fast, but they must be understood and analyzed with care.

P1 For which applications, one may use infrared detectors? Give at least 3 examples. Describe the different families of infrared technologies and give their specificities.

2 Detector characteristics

2.1 Spectral response of a photonic detector

The spectral response $R(\lambda)$ of a photodiode detector is defined for a stationary monochromatic flux Φ_λ ,

$$R(\lambda) = \frac{I_{\text{ph}}}{\Phi_\lambda} \text{ in A/W},$$

where I_{ph} is the mean current across the photodiode.

A photodiode is a quantum detector, *i.e.* a photon counter. So the current in the photodiode is easily related to the number of photons received per second, $n_{\text{ph},\lambda}$,

$$I_{\text{ph}} = \eta(\lambda) \cdot n_{\text{ph},\lambda} \cdot e,$$

where e is the electron charge and $\eta(\lambda)$ is the quantum efficiency (photon to electron conversion).

P2 Show that the spectral response of the detector is given by

$$R(\lambda) = \frac{I_{\text{ph}}}{\Phi_{\lambda}} = \frac{\lambda \cdot \eta(\lambda) \cdot e}{h \cdot c} \text{ in A W},$$

where h is the Planck constant $h = 6.626 \times 10^{-34}$ J s.

We also define the **relative** spectral response of the detector:

$$S(\lambda) = \frac{R(\lambda)}{\max R(\lambda)} = \frac{R(\lambda)}{R(\lambda_{\text{peak}})}$$

P3 Explain why, if the quantum efficiency is constant, the spectral response $S(\lambda)$ for $\lambda < \lambda_{\text{peak}}$ is a linear function as represented on Figure 2.1.

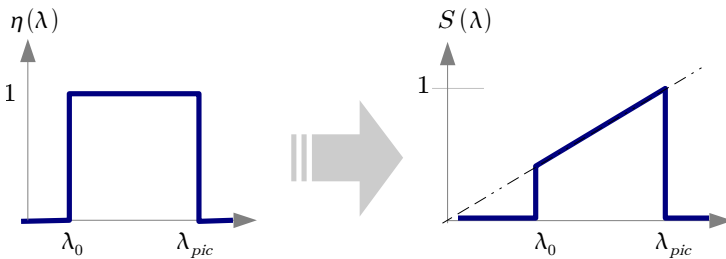

Figure 2.1: Spectral responsivity.

We will study an InSb detector whose cut off wavelength is: $\lambda_c = 5.5 \mu\text{m}$. The value corresponding to the peak of sensibility is $\lambda_{\text{peak}} = 5.3 \mu\text{m}$.

P4 Calculate the maximal response $R(\lambda_c)$ of a InSb detector at $\lambda_c = 5.3 \mu\text{m}$ assuming the quantum efficiency is equal to 1.

The relative spectral response of the studied detector is obtained by comparison with a detector which spectral response is well known. For this purpose, one may use a pyroelectric detector as a reference. It is a thermal detector that

has a constant spectral response. Some previous measurements are available on the computer.

See file `sensibilite_relative_insb.xls`.

2.2 Background infrared radiation

For IR detectors, the background photon flux detected is generally very large compared to the flux (signal) we want to measure (this explains why we need a chopper in front of our source in our setup). The black body emission of the whole scene at room temperature viewed by the detector is responsible for this large flux of background photons. This flux will be converted in a DC current, $I_{\text{ph,BG}}$. To determine this current, one needs to calculate the flux of background photons using Planck photonic black body law.

P5 Show that if the FOV (Field Of View) of the detector is 2α , the flux of photons received by the detector is:

$$n_{\text{ph,BG}} = \pi A_d \sin^2 \alpha \cdot L_{\text{ph,BG}} \text{ (in s}^{-1}\text{)},$$

where A_d is the area of the detector, and $L_{\text{ph,BG}}$ is the photonic total radiance between 2 and $5.5 \mu\text{m}$,

$$L_{\text{ph,BG}} = \int_{2 \mu\text{m}}^{5.5 \mu\text{m}} \left[\frac{dL_{\text{ph}}}{d\lambda} \right]^{T_{\text{BG}}} d\lambda \text{ (in s}^{-1} \text{m}^{-2} \text{sr}^{-1}\text{)}.$$

The spectral photonic radiance is given by

$$\left[\frac{dL_{\text{ph}}}{d\lambda} \right]^T = \frac{2c}{\lambda^4} \frac{1}{\frac{hc}{e\lambda kT} - 1} \quad (2.1)$$

where h is the Planck constant ($h = 6.626 \times 10^{-34} \text{ J s}$) and k is the Boltzmann constant ($k = 1.38 \times 10^{-23} \text{ J K}^{-1}$).

P6 Calculate $n_{\text{ph,BG}}$ for our detector (the diameter is 1 mm and the half angle $\alpha = 30^\circ$) if we assume that the quantum efficiency is 1 on the wavelength range $2 - 5.5 \mu\text{m}$. Calculate the corresponding DC current $I_{\text{ph,BG}}$.

↪ The total photonic radiance has to be calculated by integration of the spectral photonic radiance (2.1) on the wavelength range $2 - 5.5 \mu\text{m}$. This integration can be done numerically with `Matlab` or `Excel` or using the webpage: http://www.spectralcalc.com/blackbody_calculator/blackbody.php

2.3 Background photon noise limit

The fluctuation of this flux of background photons is generally the main source of noise for IR detectors (these detectors are Background Limited Infrared Photodetectors or "BLIP") .

In this case, the noise current measured in a 1 Hz equivalent Bandwidth is given by the Schottky formula :

$$i_{n,BG} = \sqrt{2eI_{ph,BG}} \text{ (in A /}\sqrt{\text{Hz)}}$$

P7 Deduce $i_{n,BG}$ from the current $I_{ph,BG}$ calculated in question **P6**.

2.4 N.E.P.: Noise Equivalent Power

The Noise-Equivalent Power (NEP) is the radiant power that produces a signal-to-noise ratio of unity at the output of a given optical detector at a given modulation frequency, operating wavelength, and equivalent noise bandwidth.

$$\text{NEP}(\lambda) = \Delta\Phi_{pp}(\lambda) = \frac{i_{\text{noise, rms}}}{R(\lambda)} \text{ in W}$$

In other words the N.E.P. gives the smallest detectable variation of IR flux.

P8 Explain why the NEP is proportional to the square root of the effective bandwidth.

P9 For a BLIP detector, explain why the NEP is proportional to the square root of its surface?

Because the NEP is proportional to the square root of the detector surface and to the square root of the ENBW (Equivalent Noise Band Width), in order to compare different IR detectors we have to define the ratio:

$$\frac{\text{NEP}(\lambda)}{\sqrt{A_d}\sqrt{\Delta f}}$$

where A_d is the detector area and Δf is the Equivalent Noise Band Width ENBW.

2.4.1 Spectral Detectivity

The detectivity, preferred by the manufacturers, is the inverse of the quantity defined above because the higher the detectivity, the better the detector is:

$$D^*(\lambda) = \frac{\sqrt{A_d}\sqrt{\Delta f}}{\text{NEP}(\lambda)} = R(\lambda) \frac{\sqrt{A_d}\sqrt{\Delta f}}{i_{\text{noise, rms}}} = R(\lambda) \frac{\sqrt{A_d}}{i_{\text{noise, rms.}@1 Hz}}$$

where $i_{\text{noise, rms.}@1 Hz}$ is expressed in $A/\sqrt{\text{Hz}}$, $D^*(\lambda)$ in $\text{cm}\sqrt{\text{Hz}}/\text{W}$, as the detector area is expressed in cm^2 .

The maximal value is obtained for λ_{peak} and is called peak detectivity (D_{peak}^*).

P10 What is the value of D_{peak}^* according to the datasheet ?

2.5 Black body Detectivity

A direct measurement of the spectral detectivity versus the wavelength is difficult. So we will first measure the Black Body Detectivity (the detector is illuminated by a black body at 500 K). Then we will measure the relative spectral response of the detector $S(\lambda)$.

The Black Body Detectivity $D_{\text{BB}}^*(T_{\text{BB}}, f, \Delta f)$ is:

$$\begin{aligned} D_{\text{BB}}^*(T_{\text{BB}}, f, \Delta f) &= R_{\text{BB}} \frac{\sqrt{A_d}\sqrt{\Delta f}}{i_{\text{noise, rms.}}(f)} \\ &= \frac{I_{\text{ph}}}{\Phi_{\text{BB}, T_{\text{BB}}}} \frac{\sqrt{A_d}}{i_{\text{noise, rms.}@1 Hz}(f)} \end{aligned}$$

in $\text{cm}\sqrt{\text{Hz}}/\text{W}$, where T_{BB} is the black body temperature, f the modulation frequency and Δf the ENBW.

P11 For which values of T_{CN} , f , Δf is the black body detectivity given in the datasheet?

Remark From the measurements of $D_{\text{BB}}^*(T_{\text{BB}}, f, \Delta f)$ **and** $S(\lambda)$ we will deduce $D^*(\lambda)$ for this detector (see paragraph 4).

3 Measurements

The circuit diagram is given in Figure 2.2.

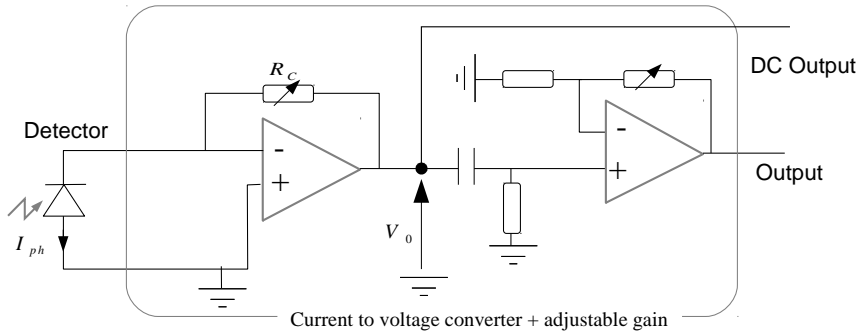

Figure 2.2: Circuit diagram.

P12 What is the name of the first stage of the detection circuit? What is the link between V_0 and I_{ph} ? What is the bias voltage? What is the function of the second amplifier? How about the RC filter between the two amplifiers?

3.1 Measurement of the current due to the background infrared radiation

↪ Connect the detector to the amplifier box and the voltmeter to the DC output. Connect the output to the oscilloscope.

↪ Pour slowly and carefully liquid nitrogen into the cryostat and wait for the signal apparition.

Q1 Measure the DC voltage. Deduce the value of $I_{ph,BG}$ and, compare it with the value determined at question **P6**.

3.2 Measurement of the detector noise

↪ Connect the output of the amplifier box to the filter box.

3.2.1 Noise measurement with an oscilloscope

↪ Display the signal on the RIGOL oscilloscope. Choose properly the value of R_c and of the different gains in order to obtain a correct signal amplitude without any saturation.

Q2 Where does this noise come from? Assuming this noise is Gaussian, measure $V_{\text{noise,rms}}$ with the oscilloscope (you can use the theoretical framework provided by the subject of Labwork 9, and we remind you that $V_{\text{noise,rms}} = V_{\text{pp}}/6$ for a Gaussian noise).

Q3 The bandwidth of the anti-aliasing filter is about 2 kHz. Assuming the noise is a white noise on this bandwidth, calculate $v_{\text{noise,rms}@1Hz}$ in a 1 Hz analysis bandwidth (rms noise voltage in $V/\sqrt{\text{Hz}}$). Deduce the current noise, $i_{\text{noise,rms}@1Hz}$, in the photodiode for an equivalent bandwidth of 1 Hz (current noise normalized in $A/\sqrt{\text{Hz}}$). Compare to the value obtained in preparation (**P7**).

3.2.2 Accurate noise measurement with a FFT spectrum analyzer

↪ Connect the signal on the 1st input channel of the LeCroy analyzer.

↪ Upload the setup file named `TPDetIR_HistBruit`. To do so, go to the menu `File>Recall Setup`.

↪ Click on the `C1` yellow frame, located just below the plot area. Check that the coupling parameter is set to `DC1MΩ`. Change the parameter value if needed.

Q4 Can we consider that the noise measured by the analyzer is Gaussian? Explain why this approximation is physically relevant.

↪ Now, upload the setup file named `TPDetIR_TFBruit` in the menu `File>Recall Setup`. Check that the coupling parameter is still set to the correct value.

Q5 Is the measured noise a white noise? Was it expected?

Q6 Explain the role of the anti-aliasing filter. Where do you see its influence? Why is it necessary for this measurement? How should we choose the sampling frequency?

The background photon noise (detector noise) and the amplification noise are both responsible for the measured noise. These noise sources are statistically independent so:

$$v_{\text{total,rms}} = \sqrt{v_{\text{noise,rms}}^2 + v_{\text{ampli,rms}}^2}$$

↪ Go to the `Cursors` menu and select `Horizontal Abs.` Display the cursor settings in `Cursors>Cursor Setup` and select `Hz` as the `X - axis` parameter. The x-coordinate (frequencies) of the cursor is displayed on the right of the screen, its y-coordinate is displayed in the red and blue frames intitled `F1` and `F2` respectively. We remind you that $P_{\text{dBm}} = 10 \log \left(\frac{P}{1\text{mW}} \right)$ where $P = V^2/1\text{M}\Omega$.

Q7 Measure the noise voltage at the output for 500 Hz. Then, for the same frequency, measure the noise voltage at the output when the detector is disconnected. Deduce the detector noise voltage $v_{\text{noise,rms}}$ and the current noise of the detector $i_{\text{noise,rms}}$.

Q8 Note the value of the equivalent noise bandwidth Δf displayed in the `FFT` panel that appears when you click on the red `F2` frame. Deduce the noise current of the detector in 1 Hz bandwidth $i_{\text{noise,rms}@1\text{Hz}}$. Compare to the value obtained in preparation (**P 7**). Is the detector BLIP?

3.3 Measurement of the black body response of the IR detector

To measure the black body response of the IR detector,

$$R_{\text{BB}} = \frac{\Delta I_{\text{ph}}}{\Delta \Phi_{\text{BB}}} \text{ in } \text{A} / \text{W}$$

we will have to:

- determine precisely the flux variation received by the detector,
- measure carefully the photocurrent induced by this flux variation.

3.3.1 Set-up

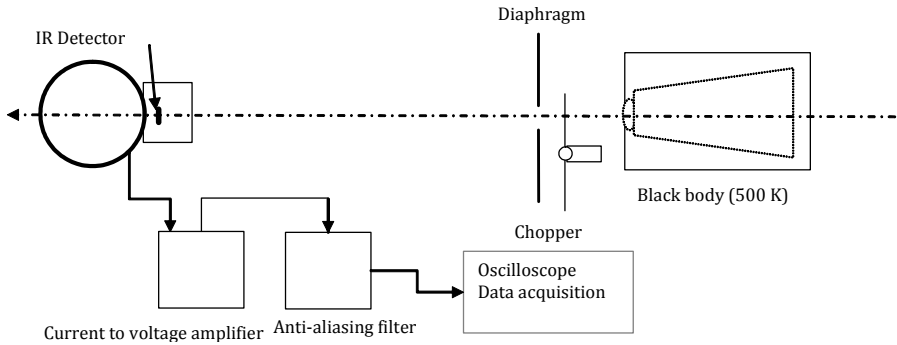

Figure 2.3: Set-up

When the chopper is turning, the detector sees through the diaphragm alternately a black blade at room temperature or the black body at 500 K.

Do not change the temperature settings of the black body!

3.3.2 First measurement using an oscilloscope

↪ Set the modulator frequency to 500 Hz.

↪ Place the detector precisely at 1 meter from the diaphragm (Detector is at $(9 \pm 1)mm$ behind the window).

↪ Align carefully the Black Body, the diaphragm (we will choose a diameter $\phi = 5$ mm) and the detector.

↪ Optimize the signal by improving your alignment.

Q9 Measure the peak to peak voltage without anti-aliasing filter.

The flux variation $\Delta\Phi(t)$ is periodic and can thus be decomposed as a Fourier series. One can then calculate the RMS value of its fundamental component $\Delta\Phi_{\text{rms}}$. One can show that RMS value is related to the peak to valley of the flux variation Φ_{pp} by the Modulation Factor (M.F.):

$$\text{MF} = \frac{\Delta\Phi_{\text{rms}}}{\Phi_{\text{pp}}} = \frac{\Delta\Phi_{\text{rms}}}{\Phi_{\text{max}} - \Phi_{\text{min}}} \quad (2.2)$$

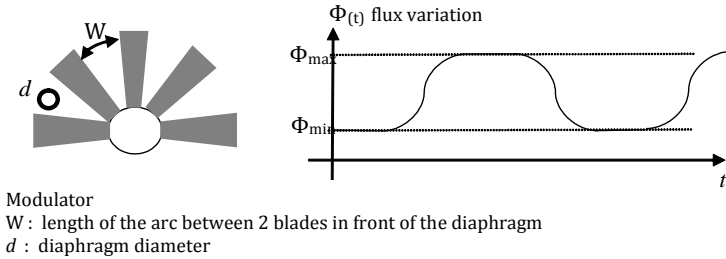

Figure 2.4: Chopper

For a square signal (case $d \ll W$):

$$MF = \frac{\sqrt{2}}{\pi} = 0.45$$

Q10 Show that the modulation factor for a square signal is:

$$MF = \frac{\Delta V_{\text{rms}, 500 \text{ Hz}}}{V_{\text{peak to peak}}} = \frac{\sqrt{2}}{\pi} = 0.45$$

Deduce a value of $\Delta V_{\text{rms}, 500 \text{ Hz}}$.

Q11 Deduce a value of $\Delta I_{\text{BB}, \text{rms}, 500 \text{ Hz}}$.

3.3.3 Measurement of the signal obtained by the FFT method

↪ Add the anti-aliasing filter (low-pass filter, cut-off frequency of 2 kHz) and connect the output signal to the LeCroy analyzer.

↪ Go to the menu `File>Recall Setup` and upload the file `TPDetIR TF Signal`. The P2 measurement channel gives the amplitude of the highest peak, the one at 500Hz.

Q12 Measure the RMS voltage after the filter at 500Hz.

↪ Vary slightly the chopping frequency with an amplitude of $\pm 20\text{Hz}$.

Q13 Note the effective value of the highest peak measured by the analyzer during this variation. Explain the origin of these fluctuations. What is the influence of the acquisition window, the sampling frequency, F_e , and the influence of the number of acquired points N_e ? Explain why the “flat top” window is theoretically well fitted for this kind of measurement (you can use the appendix for your explanations).

↪ Set back the frequency to 500Hz. In the FFT panel of F2 channel, select the *Flat Top* window.

Q14 Measure the amplitude of the 500Hz peak. Knowing the gain of the amplifier and of the filter (in V / A), measure the current, $\Delta I_{\text{BB, rms, 500 Hz}}$ through the photodiode. Evaluate the accuracy of this measurement.

↪ Check your result with the lab instructor.

3.3.4 Determination of the flux variation received by the IR detector

Calculation of the peak to peak flux variation

Q15 Measure the diaphragm - detector distance and calculate the etendue between the detector and the diaphragm (the InSb detector diameter is 1 mm).

The black body radiance follows the Stefan law:

$$L = \frac{\sigma T^4}{\pi}$$

with $\sigma = 5,67 \cdot 10^{-8} \text{ W / m}^2 \cdot \text{K}^4$

Q16 Calculate the peak to peak flux variation received by the IR detector $\Delta \Phi_{\text{BB, pp}}$.

Calculation of the effective variation of the flux received by the detector

Q17 Using Eq. (2.2), calculate $\Delta \Phi_{\text{rms, 500 Hz}}$ received by the detector.

3.3.5 Black body response of the detector

Q18 Calculate the black body response of the IR detector $R_{\text{BB}} = \frac{\Delta I_{\text{ph}}}{\Delta \Phi_{\text{BB}}}$

↪ Check your result with the lab instructor.

3.3.6 Calculation of the black body detectivity

Q19 Deduce the black body detectivity $D_{\text{BB}}^*(T_{\text{BB}}, f, \Delta f)$. Evaluate the accuracy of your measurement.

The detector noise is normally mainly due to the photon noise of the ambient photons. In this case, the noise of the detector depends on the field of view (FOV).

Q20 Explain why the noise of the detector depends on the FOV. How should $D_{\text{BB}}^*(T_{\text{BB}}, f, \Delta f)$ be corrected to be compared with a 2π steradian detector?

4 Analysis of the measurements

In this section, no measurement is required. However, you will need the file `sensibilite_relative_insb.xls` which is saved on the computer of the room. Do not forget to make a copy of the file.

Spectral Response and spectral detectivity

With the measurements of the black body Response, R_{BB} and the relative spectral Response, the spectral response can be deduced:

$$\gamma = \frac{R(\lambda_{\text{peak}})}{R_{\text{BB}}}$$

The photonic current is given by

$$\Delta I_{\text{ph}} = R_{\text{BB}} \Delta \Phi_{\text{BB}}$$

with :

$$\Delta \Phi_{\text{BB}} = \text{MF} \times \frac{\sigma}{\pi} (T_{\text{BB}}^4 - T_{\text{BG}}^4) U$$

where U is the etendue, MF is the modulation factor, BB refers to the blackbody temperature and BG to background temperature.

E1 Explain why the photonic current can also be calculated by integration of the black body radiance :

$$\begin{aligned} I_{\text{ph}} &= MF \times U \times \int_0^{\infty} R(\lambda) \left(\left[\frac{dL}{d\lambda} \right]_{\text{BB}}^{T_{\text{BB}}} - \left[\frac{dL}{d\lambda} \right]_{\text{BG}}^{T_{\text{BG}}} \right) d\lambda \\ &= MF \times U \times R(\lambda_{\text{peak}}) \int_0^{\infty} S(\lambda) \left(\left[\frac{dL}{d\lambda} \right]_{\text{BB}}^{T_{\text{BB}}} - \left[\frac{dL}{d\lambda} \right]_{\text{BG}}^{T_{\text{BG}}} \right) d\lambda \end{aligned}$$

where $\left[\frac{dL}{d\lambda} \right]_{\text{BB}}^{T_{\text{BB}}}$ and $\left[\frac{dL}{d\lambda} \right]_{\text{BG}}^{T_{\text{BG}}}$ are the spectral radiances of the black body at temperature at T_{BB} and T_{BG} , given by :

$$\left[\frac{dL}{d\lambda} \right]_{\text{BB}}^T = \frac{2hc^2}{\lambda^5} \frac{1}{\frac{hc}{\lambda kT} - 1}$$

where λ expressed in m, $\frac{dL}{d\lambda}$ in $(\text{W} \cdot \text{m}^{-2} \cdot \text{sr}^{-1}) / \text{m}$

E2 Deduce the ratio γ :

$$\gamma = \frac{\frac{\sigma}{\pi} (T_{\text{BB}}^4 - T_{\text{BG}}^4)}{\int_0^{\infty} S(\lambda) \left(\left[\frac{dL}{d\lambda} \right]_{\text{BB}}^{T_{\text{BB}}} - \left[\frac{dL}{d\lambda} \right]_{\text{BG}}^{T_{\text{BG}}} \right) d\lambda}$$

E3 Perform this calculation using Excel.

E4 Calculate $R(\lambda_{\text{peak}})$ and give the representation of the spectral Response $R(\lambda)$. Plot also the spectral quantum efficiency curve.

E5 Using γ , calculate $D_{\text{peak}}^* = D^*(\lambda_{\text{peak}})$ and plot the spectral detectivity curve $D^*(\lambda)$.

5 Writing down the report

In your report, you do not have to linearly describe your measurement protocols and your results. However, you should write a well structured document (between 2 and 6 pages maximum with an introduction, a conclusion, several parts, etc.) where you will summarize:

- the major concepts related to the technology you studied in the labwork,
- the key points and challenges of the characterization of an IR detector,

- your conclusions of the performance of the detector you studied during the labwork.

Your comments should be based on your measurements. You may also compare your observations on the infrared technology with what you know about sensors in the visible range.

Appendix 1 - Black body spectral radiance

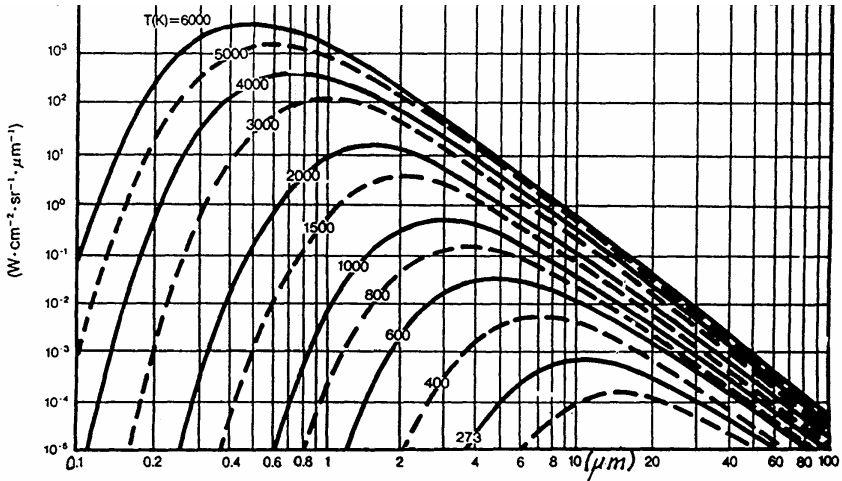

Figure 2.5: Black Body spectral radiance

Appendix 2 - Atmospheric transmittance

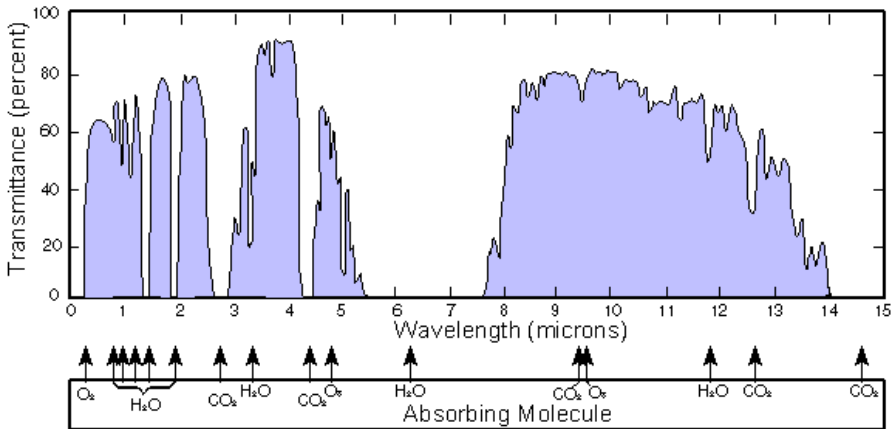

Figure 2.6: Atmospheric transmittance

Appendix 3 - Spectral detectivity

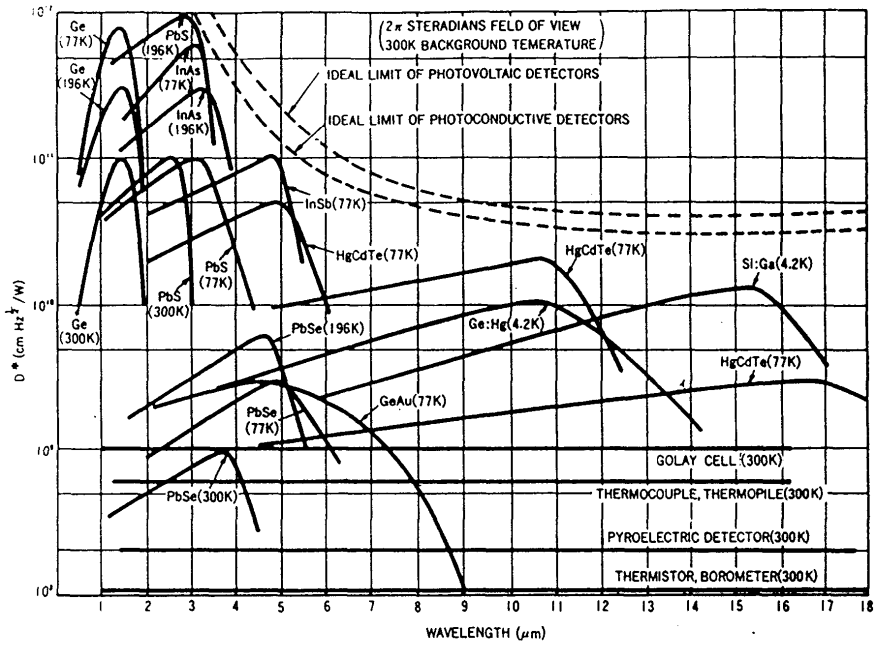

Figure 2.7: Spectral detectivities of IR detectors

B 3

CMOS sensor

Version: January 24, 2024

Questions from P1 to P5 should be prepared before the session.

Contents

1	Introduction	39
2	Preliminary questions	41
3	Matlab interface and sensor learning	42
4	Measurement of the read-out noise	44
5	Study of the dark signal	44
6	Study of the sensor linearity and photon noise	45
7	Measurement of the sensor spectral response	47
8	Synthesis	48

1 Introduction

Nowadays, the vast majority of cameras produced are CMOS (Complementary Metal Oxide Semiconductor) cameras: they have imposed themselves in front of CCD (Charge-Coupled Device) cameras. The main difference between the two technologies is that each pixel of a CMOS sensor possesses its own read-out circuit (charge-voltage converter and amplifier), directly next to the photosensitive area. Compared to the CCD technology, the benefits of the CMOS technology are:

- Sensors easier to produce and thus cheaper,
- Low consumption,

- Faster data reading,
- Each pixel can be individually controlled,
- Possibility to do image processing directly at the sensor level (definition of regions of interest (ROI), binning, filtering, ...)

The drawbacks of the technology are a lower dynamic range and a higher noise level.

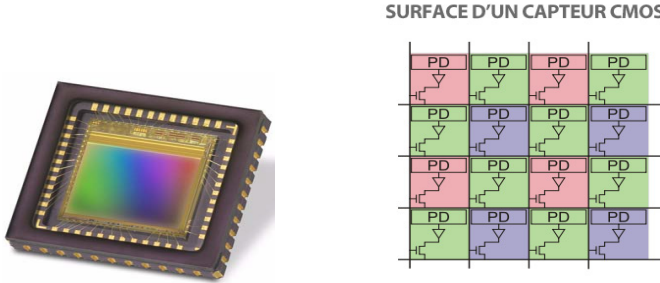

Figure 3.1: Left - CMOS e2V sensor studied during this session. Right - diagram of the general principle of CMOS sensors.

The goal of this session is to measure the characteristics of an industrial μ Eye camera, equipped with a CMOS sensor, manufactured by e2V (1.3 Mpixels, $5.3 \times 5.3 \mu\text{m}^2$ pixels). Figures 3.2 and 3.3 show some characteristics of the sensor. We are specifically interested in the sensor linearity, the read-out noise, the dark signal and the photon noise. The measured values will be compared to the data given by the manufacturer.

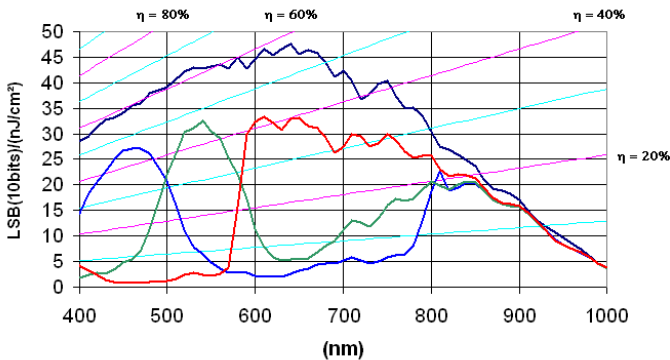

Figure 3.2: Extract from the CMOS e2V sensor datasheet - spectral response.

Capteur EV76C560 Typical electro-optical performance @ 25°C and 65°C, nominal pixel clock

Parameter		Unit	Typical value	
Sensor characteristics	Resolution	pixels	1280 (H) × 1024 (V)	
	Image size	mm inches	6.9 (H) × 5.5 (V) - 8.7 (diagonal) ≈ 1/1.8	
	Pixel size (square)	μm	5.3 × 5.3	
	Aspect ratio		5 / 4	
	Max frame rate	fps	60 @ full format	
	Pixel rate	Mpixels / s	90 -> 120	
	Bit depth	bits	10	
Pixel performance			@ 25°C	@ 65°C
	Dynamic range	dB	>62	>57
	Qsat	ke-	12	
	SNR Max	dB	41	39
	MTF at Nyquist, λ=550 nm	%	50	
	Dark signal ⁽¹⁾	LSB ₁₀ /s	24	420
	DSNU ⁽¹⁾	LSB ₁₀ /s	6	116
	PRNU ⁽²⁾ (RMS)	%	<1	
Responsivity ⁽³⁾	LSB ₁₀ /(Lux.s)	6600		
Electrical interface	Power supplies	V	3.3 & 1.8	
	Power consumption: Functional ⁽⁴⁾ Standby	mW μW	< 200 mW 180	

1. Min gain, 10 bits.
2. Measured @ Vsat/2, min gain.
3. 3200K, window with AR coating, IR cutoff filter BG38 2 mm.
4. @ 60 fps, full format, with 10 pF on each output.

Figure 3.3: Extract from the CMOS e2V sensor datasheet.

2 Preliminary questions

Each pixel of this CMOS sensor can be modeled by a photodiode and its pre-amplification circuit. The output voltage of each pixel is then converted by a 10-bits analog-to-digital converter into a numerical value. This data is then sent, pixel by pixel, to the computer by an USB link.

P1 Draw the acquisition chain with a focus on the kind of information that go from a block to another.

The maximum number of photoelectrons per pixel (*Full Well*) is a key parameter. The Full Well value sets the dynamic range and the signal to noise ratio of the sensor.

P2 According to the datasheet, the Full Well value is 12000e-. Knowing that the signal is digitized over 10 bits, what is the equivalence between 1 bit-level and the number of electrons?

Remark: This conversion factor (e-/bit-level) is often referred to as *Gain* in datasheets and is expressed in e-/ADU (Analog-Digital Units).

P3 Assuming that the photon noise is the predominant source of noise, the signal to noise ratio (SNR) is directly linked to the Full Well value. Calculate the SNR in dB and compare your result to the value given by the manufacturer (41dB).

The datasheet gives the following spectral response for the sensor: 45LSB (10bits) for 1 nJ/cm^2 for a wavelength of 600 nm (see Figure 3.4). This corresponds to a quantum yield of 60%.

P4 Confirm that this quantum yield value is indeed compatible with the given spectral response value.

3 Matlab interface and sensor learning

3.1 Matlab processing

The camera is controlled using a graphic interface developed on Matlab, called `GuiCamera`.

Remark : In order to optimize the processing of the 10-bits acquired data of each pixel, only the **8 most significant bits** are stored by the `GuiCamera` interface.

P5 What is the conversion factor you need to apply to obtain the real value acquired on the sensor compared to the data stored by the `GuiCamera` program ?

3.2 Graphical interface

↪ Start Matlab.

↪ On the Matlab command window, enter: `>> GuiCamera`

↪ Initialize the camera.

↪ In the main window, click on the option : *Zone d'intérêt (AOI) au centre de la caméra.*

↪ Click on paramètres to open the property window (see Figure 3.2).

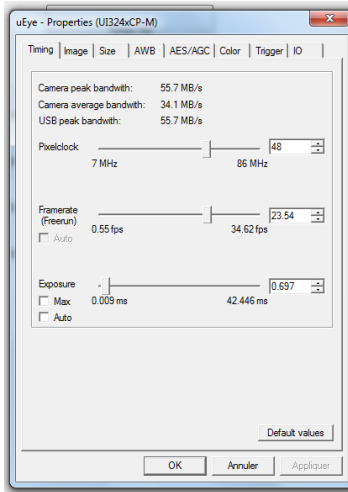

Figure 3.4: Acquisition setting window

↪ Set the following acquisition parameters:

- In the *Image* tab, check that the Master Gain is set to 0 (Gain 1.00x) and that the Gain, Black Level (offset) and the Gamma Auto-correction boxes are unchecked.
- Set the Black Level to 255.
- In the *Size* tab, check that the binning along x and y is set to the normal value.
- In the *Timing* tab, set the PixelClock to 30 MHz.

3.3 Comparison with and without camera lens

In its current use in imaging, it is essential to add a lense in front of the camera sensor.

↪ A camera lens is available on the table : attach it to the camera.

Q1 What differences can be observed in the image recorded by the camera with and without lens ? For this lab work, you will be using the camera sensor without a lens : why ?

4 Measurement of the read-out noise

The read-out noise is an electronic noise that appears during the conversion of the photoelectrons into voltage. This voltage is then digitized over 10 bits. To measure this noise, the sensor should receive no signal at all, with an integration time set as small as possible (to suppress the dark signal).

↪ Put the cap on the sensor. Set the integration time to its minimum value, in the `Timing` tab of the `Paramètres` of the sensor.

↪ Display the image histogram using the `Histogramme` button.

Q2 Read off the mean value and the standard deviation (*Ecart-Type*) above the histogram. What do these two values mean ?

↪ In the `Image` tab, modify the value of the Black Level and observe the effect on the histogram. The Black Level is also called Bias. Observe the histogram for a Black Level value ranging from 0 to 255.

Q3 Explain the influence of the Black Level value. For the maximum value (255), give the average value of the signal on the image. The read-out noise is the fluctuation around this average value.

↪ Read off the value of the read-out noise observed on the histogram.

Remark : throughout the rest of the labwork session, you will set the Black Level to 255.

5 Study of the dark signal

We now consider images acquired in the absence of any signal, for an increasing value of the integration time. These images are often referred to as Dark images.

The sensor does not receive any light and you are going to analyze its response depending on the integration time.

↪ Read off the mean value and the standard deviation of the gray level of the histogram, for an integration time ranging from 0 to 2 seconds (with a 250ms step).

↪ Plot the curve of the dark signal as a function of the integration time (do not forget to subtract the Black Level).

Q4 Compare your dark signal value to the one given by the manufacturer.

↪ Observe the images for long integration times. Some pixels (referred to as Hot Pixels) exhibit a much stronger signal. It is not a temporal noise but a spatial heterogeneity of the dark signal. Does the shape of the histogram seem to be gaussian ?

Q5 Compare the value of the standard deviation to the Dark Signal Non Uniformity (DSNU) value given by the manufacturer. How could you reduce this value ?

6 Study of the sensor linearity and photon noise

The CMOS sensor is now placed in front of an integrating sphere in order to be uniformly illuminated. The images obtained in this case are often called Flat.

↪ Set the integration time to 1 ms.

↪ Power the integration sphere in order to obtain a gray level mean of 150.

6.1 Spatial analysis - Linearity

In order to measure the linearity of the sensor, one can measure the mean value of the signal as a function of the integration time (do not forget to subtract the read-out noise).

↪ Read off the mean value and the standard deviation of the signal for an integration time ranging from 0 to 2 ms (by step of 250 μ s).

Q6 What can you say about the last point ? How can you find the Full Well value on your graph ?

↪ Plot the mean value of the signal as a function of the integration time.

Q7 Is the response of the sensor linear?

6.2 Temporal analysis - Photon noise

The photon noise can be estimated by measuring the signal temporal fluctuation of a pixel for different incident photon fluxes on the sensor.

↪ Set the integration time to 200 μ s.

↪ Power the integration sphere in order to obtain a gray level mean of 128.

↪ Observe the fluctuation of the signal of a pixel for this signal level.

Q8 Is the signal random ? What is the shape of the histogram ?

Remark : In order to obtain good statistical results, the observation must be done for a large number of points (between 500 to 1000).

↪ Repeat this operation for different gray levels (64, 128, 192...) and plot the mean level as a function of the variance of the signal.

Q9 Can the measured noise be considered to be photon noise? Why?

If the noise is indeed photon noise (*i.e.* Poisson noise), the fluctuation of the number of photo-electrons per pixel is given by its standard deviation or its variance:

$$\sigma_{N_e}^2 = \langle N_e \rangle$$

The number of photo-electrons is then digitized $S_{10\text{bits}}$:

$$S_{10\text{bits}} = \frac{N_e}{G}$$

where G is the conversion factor (gain) in electrons per bit-level (e- / ADU).

The mean value of the digital signal is then

$$\langle S_{10\text{bits}} \rangle = \frac{\langle N_e \rangle}{G}$$

and its variance is given by

$$\sigma_{S_{10\text{bits}}}^2 = \frac{\sigma_{N_e}^2}{G^2}$$

It is thus possible to find the conversion factor (gain) in electrons per bit-level (e- / ADU) from the previous measurement:

$$G = \frac{\langle S_{10\text{bits}} \rangle}{\sigma_{S_{10\text{bits}}}^2}$$

Q10 Estimate the value of the conversion factor and compare your result with the value obtained in P2.

Q11 Propose an explanation to justify the difference between the temporal fluctuations of a pixel's signal and the noise that you get by studying the histogram of the 200×200 -pixel area.

7 Measurement of the sensor spectral response

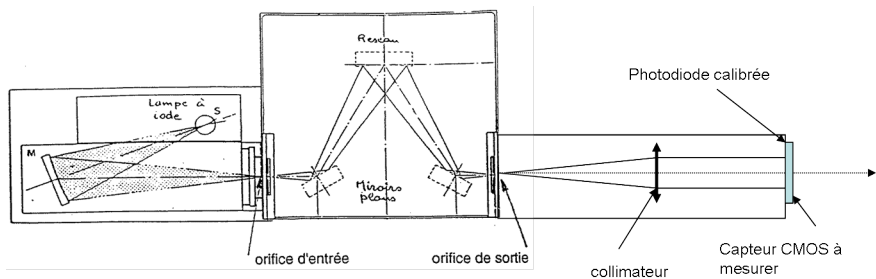

Mesure de sensibilité spectrale

Figure 3.5: Schematic diagram of the measurement bench using a monochromator

The monochromator allows one to choose the wavelength of the light sent on the sensor. The input and output slits are 2-mm wide which gives a spectral width of the order of 30 nm. After the monochromator, a collimator allows to illuminate the studied sensor under normally incident light. We use a PIN 10-D photodiode with a photosensitive area of 1cm^2 to measure the illumination received by the sensor. The sensitivity of this photodiode is given in Figure 3.6.

↪ Power the monochromator light with a voltage around 20 V.

↪ Using the photodiode, measure the irradiance (in W/cm^2) for the following wavelength: 500, 600, 700, 800, 900 nm.

↪ Replace the photodiode with the CMOS sensor. Set an appropriate integration time. Measure the signal intensity in the center of the image for these wavelengths.

↪ Deduce from your measurements the spectral response of the sensor in gray level as a function of the received energy per cm^2 $\left(\frac{\text{ADU}}{\text{nJ}/\text{cm}^2}\right)$

Q12 Plot the curve and compare it with the datasheet.

Q13 What is the quantum yield for these wavelengths? Plot the quantum yield as a function of the wavelength.

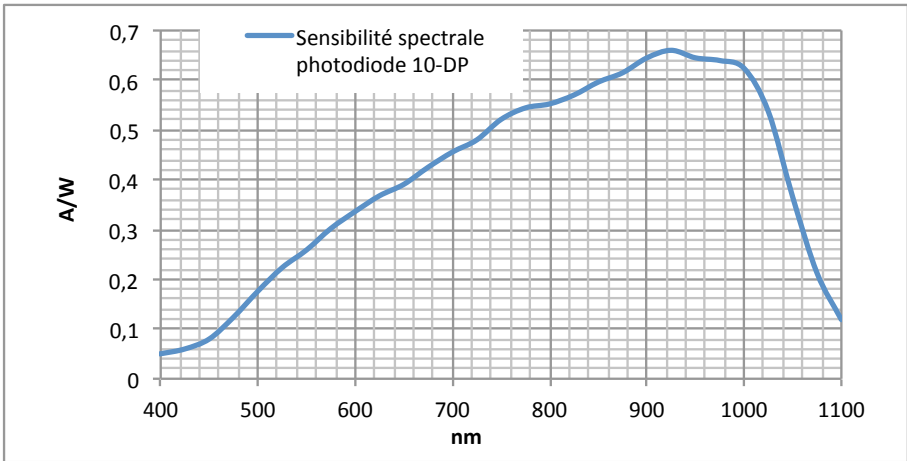

Figure 3.6: Spectral response of the calibration photodiode

8 Synthesis

In a brief report (2 pages maximum - except curves), you will explain to a manufacturer who wants to test and calibrate his new CMOS sensor the different steps he has to follow and the curves he has to produce. Your description will be based on your experimental results.

B 4

Thermal camera

Version: January 24, 2024

Do not forget to prepare the preliminary questions before the lab. Some of them can be asked during the oral examination.

Contents

1	Objectives	50
2	Presentation of the cameras	50
3	Reminders on the physics of an infrared scene	51
4	Getting started with the cameras	52
5	Influence of emissivity	53
6	Measuring the performance of infrared cameras	54
7	Absolute temperature measurement	57
8	Non destructive testing (NDT)	58
	Annexe 1: Blackbody law	60
	Annexe 2 : MRTD measurement	61

This lab will allow you to take in hand two infrared cameras of microbolometer technology (figure 4.1), to characterize their performances then to approach two applications of infrared imaging.

The first part of the lab is devoted to the discovery of infrared and the highlighting of certain properties of materials in the infrared (emissivity, transparency/opacity...). Then, you will evaluate the performance of both cameras by measuring their NETD (noise equivalent temperature difference). You will then focus on two applications of infrared imaging: absolute temperature measurement (infrared thermography) and non-destructive testing.

The lab report is due one week after the session. It must contain a description of the various measurements taken and an answer to all questions asked

in the statement. Do not hesitate to include infrared images in the report to illustrate your point.

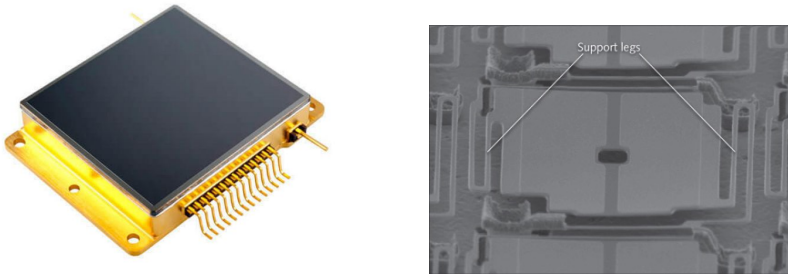

Figure 4.1: Left : Microbolometer Focal Plane Array (credit : www.ulis-ir.com). Right: a pixel (credit : <http://www.laserfocusworld.com>).

1 Objectives

At the end of this session, you should be able to:

- explain the importance of the emissivity in infrared thermography;
- explain the working principles of the bolometric camera;
- evaluate the performance of an infrared camera for thermography, this means to be able to:
 - identify the parameters of interest (NETD, spatial noise, MRTD, . . .);
 - propose procedures to measure such parameters;
 - evaluate the uncertainty of the measurements;
- evaluate the precision of the temperature measurements carried out by such a camera.

2 Presentation of the cameras

Be careful, infrared cameras are fragile and VERY expensive! Handle them with care...

You will use two microbolometer cameras of different generations. Their characteristics are given in Table 4.1. Remember that the NETD (noise equivalent temperature difference) is the smallest temperature difference detectable by the camera (assuming it observes a blackbody). It is often called "thermal sensitivity" by manufacturers, or "thermal resolution" (by abuse of language).

	Camera AGEMA 570	Camera FLIR A655sc
Technology	microbolometer	microbolometer
Spectral band	8 – 14 μm	8 – 14 μm
Format	320 \times 240 pixels	640 \times 480 pixels
Pitch	50 μm	17 μm
Focal length	40 mm	24.6 mm
f-number	1	1
NETD @30 °C	< 150 mK	< 30 mK
Field of view (FOV)	24° \times 18°	25° \times 19°
Frame rate	2.7 Hz	50 Hz full frame

Table 4.1: Characteristics of the two cameras.

P1 Recall the working principle of a microbolometer focal plane array.

P2 Justify the choice of using the W as the flux unit in this lab (as opposed to s^{-1} or lumens).

3 Reminders on the physics of an infrared scene

In general, the spectral luminance of any object X at temperature T is given by:

$$\left[\frac{dL}{d\lambda} \right]_X^T(\lambda) = \varepsilon(\lambda) \cdot \left[\frac{dL}{d\lambda} \right]_{\text{BB}}^T + \frac{\rho(\lambda)}{\pi} \cdot \frac{dE}{d\lambda}(\lambda), \quad (4.1)$$

where $\left[\frac{dL}{d\lambda} \right]_X^T$ is expressed in $W \cdot \text{m}^{-2} \cdot \text{sr}^{-1} \cdot \text{m}^{-1}$ (radiant units),

$\varepsilon(\lambda)$ is the emissivity of the object, which depends a priori on the wavelength, on the temperature of the object, on the surface roughness, etc,

$\left[\frac{dL}{d\lambda} \right]_{\text{BB}}^T$ is the spectral luminance of a blackbody at the same temperature,

$\rho(\lambda)$ is the diffuse reflection factor (also called albedo) of the object,

$\frac{dE}{d\lambda}$ is the spectral irradiance received by the object X coming from the environment.

This expression gives rise to two terms: the first one is the object's own luminance, proportional to that which would be emitted by a blackbody at the same temperature, the proportionality factor being the emissivity (ability of a material to radiate). This term is often referred to as an **emissive contribution**. The second term represents the diffuse reflection of ambient illumination, and is called the **reflective contribution**.

Materials with low emissivity (poor blackbodies)	Materials with medium emissivity	Materials with high emissivity (excellent blackbodies)
Polished gold: 0.01-0.1 Polished sheet of metal: 0.01-0.05 Polished aluminium: 0.04 Chrome: 0.1	Rusty aluminium: 0.2-0.4 Rusty sheet of metal: 0.3-0.5 Basalt: 0.7	Paint: 0.9-0.95 Wood: 0.9-0.95 Brick: 0.93 Concrete: 0.95 Cloth: 0.95 Paper (any color): 0.95 Human skin: 0.95-0.98

Table 4.2: Emissivity values in the 8 – 14 μm spectral band.
Sources : Wikipedia.org, Raytek.fr, Woehler.com, Op-
tris.fr.

In the visible domain, the first term is negligible, and we find in the second term Lambert's law seen during the photometry course. In the infrared domain, we often tend to think that the first term is always dominant: we will see that this is not always the case.

It is interesting to note that at a given wavelength we always have: $\epsilon + \rho + \tau = 1$ (energy conservation, with τ the transmission factor of the object under consideration, and using the fact that the absorptivity α is equal to the emissivity ϵ second law of Kirchhoff). Assuming that $\tau = 0$ (opaque material), we have: $\epsilon = 1 - \rho$. In addition, if we make the hypothesis that emissivity is independent of the wavelength in the spectral band of interest (8 – 14 μm in our case), we can rewrite 4.1 under the form:

$$L_X^T = \epsilon \cdot L_{\text{BB}}^T + \frac{1 - \epsilon}{\pi} \cdot E, \quad (4.2)$$

where L_X^T , L_{BB}^T and E are now integrated radiometric quantities in the 8 – 14 μm spectral band. This new formulation shows a "communicating vase" effect between the emissive and reflective contribution.

As an indication, Table 4.2 summarizes some emissivity values in the 8 – 14 μm spectral band.

4 Getting started with the cameras

Each camera is connected to a computer equipped with suitable software: laptop + ThermaCam software for the AGEMA camera, and fixed station + Re-

searchIR software for the FLIR camera. A simplified manual of both softwares is available in the room.

↪ Image the same area of the room with both cameras. Adjust the focus and choose a grey color scale for both cameras.

Q1 Compare qualitatively the images obtained (think in particular of observing how homogeneous areas of the scene are reproduced).

↪ Present the available samples in front of the infrared camera: golden mirror, germanium window, ZnSe window, plastic cover, plexiglass plate, trash bag. Also observe a face (if possible with glasses) and the bulb of the desk lamp (lit, then turned off).

↪ Save a few images showing:

- That a transparent material in the visible can be opaque in the infrared.
- that an opaque material in the visible can be transparent in the infrared.
- a thermal imprint, i.e. the trace left in the infrared by a hot element placed a few seconds on a cold element (or vice versa)
- an infrared reflection phenomenon

Q2 Comment on these images.

↪ Measure the temperature of the palm of your hand.

Q3 Comment on the value obtained.

5 Influence of emissivity

In this part, only the FLIR camera is used.

There is a copper plate with two different surface treatments: left, matt black paint, and right, sandblasting. This plate is temperature controlled by a thermoelectric module.

↪ Adjust the temperature of the copper plate to about 40 °C using the calibration chart available in the room. Image the copper plate by placing the FLIR A655sc camera at a distance of about 1m. Select two measuring zones in the left and right half of the copper plate respectively. Record the temperature for each measurement area and the raw signal.

Q4 Using the concept of emissivity, explain the observed temperature difference.

↪ Set the plate temperature to approximately 20 °C.

Q5 Why is there an inversion of contrast compared to the previous measurement? At which temperature does this contrast inversion occur ?

↪ Measure again the temperatures displayed for each part of the plate.

Q6 Using equation (4.2), show that it is possible to estimate emissivity with the following formula:

$$\varepsilon = \frac{L_{\text{right}}^{40\text{ }^\circ\text{C}} - L_{\text{right}}^{20\text{ }^\circ\text{C}}}{L_{\text{left}}^{40\text{ }^\circ\text{C}} - L_{\text{left}}^{20\text{ }^\circ\text{C}}} \quad (4.3)$$

Q7 Deduce the emissivity value of sandblasted copper from your measurements.

Another method - empirical - to determine the emissivity of the sandblasted part is to modify the emissivity of this zone in the software so as to obtain the same temperature as the left part with an emissivity of 1.

↪ Set the copper plate temperature to approximately 30 °C. Using this method, determine a second measurement of the emissivity of sandblasted copper.

Q8 Compare with the first measurement. Which experimental parameter must be entered to correctly measure emissivity with this second method?

Q9 Based on the measurements in this section, what advice would you give to someone who wants to measure the temperature of metal elements?

6 Measuring the performance of infrared cameras

6.1 NETD measurements

The noise equivalent temperature difference (or NETD for Noise Equivalent Temperature Difference) indicates the **thermal sensitivity** of a camera, i.e. its ability to distinguish small temperature variations.

Suppose a camera observes a blackbody large enough to cover several pixels (see figure 4.2). By definition, the NETD of the infrared camera is the

blackbody temperature difference that results in a signal variation equal to the standard deviation σ_s (rms) of the noise:

$$\Delta T = \text{NETD} \quad \text{si} \quad |V_{i,j}(T + \Delta T) - V_{i,j}(T)| = \sigma_s \quad (4.4)$$

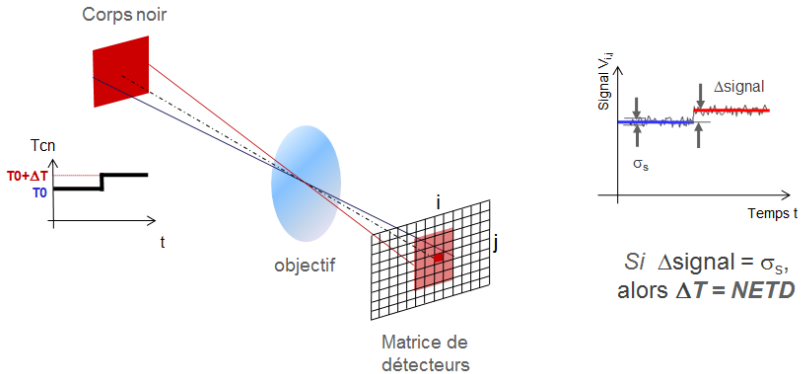

Figure 4.2: Illustration of the concept of NETD.

The NETD depends on the noise of the detector (NEP: Noise Equivalent Power, or flux equivalent au bruit in French) but also on the characteristics of the optics (in particular transmission and aperture number). The NETD is therefore a figure of merit of the camera as a whole (optics + detector).

↪ Adjust the temperature of the blackbody to 30 °C by taking care to wait until it stabilizes. Define a temperature measurement point and a wide area covering about half the surface of the blackbody.

↪ Record the temperature evolution measured in both zones over a period of 1 minute. Export the data to Excel.

Q10 Measure the standard deviation, and therefore the NETD, on the signal coming from the pixel alone. Do the values found correspond to the performance figures announced by the manufacturers? Why ?

In an imaging system, it is common to improve the signal-to-noise ratio using spatial averaging. Measure the standard deviation on the signal coming from the wide area, and therefore the new thermal sensitivity, always for a duration of 1 minute.

Q11 Shouldn't we see a greater improvement in the sensitivity? Suggest an explanation.

Q12 Why does the manufacturer announce a NETD value “ at 30 °C ” ? In other words, why does the NETD depend on the black body temperature ?

6.2 MRTD measurements

As noted above, the NETD quantifies only the camera's **thermal sensitivity**, without taking into account any limitations related to camera **resolution**. However, the scene observed by the camera may include high spatial frequencies (fine details), potentially poorly reproduced by the optics (if the fine details are smaller than the Airy spot) or by the detector array (if the fine details are smaller than the pixel size). This is where the **MRTD (Minimum Resolvable Temperature Difference)** comes in. It is measured by means of a differential blackbody equipped with a pattern of standardized shape, made up of 7 bars (or 3 cycles and a half) alternately cold and hot. The MRTD measurement is done by observing the disappearance of the bars of the test pattern in the image when the temperature difference becomes too small. The MRTD thus takes into account the scene (space-frequency composition), the monitor and the observer: it is a parameter representative of the complete optronic chain (and not just of the camera).

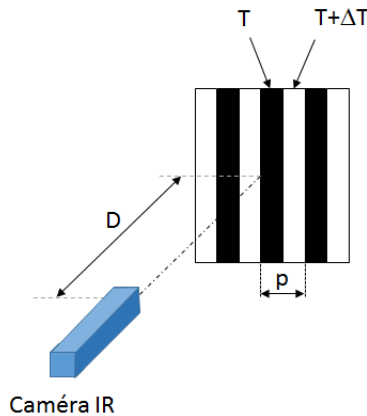

Figure 4.3: Principle of the MRTD measurement.

↪ Position the pattern with a period $p = 2.55$ mm in front of the blackbody. Set the temperature of the blackbody to 1 °C above the target temperature

(which is indicated on the blackbody controller, upper dial). Set the FLIR camera 1m from the test pattern and adjust the focus. Release the temperature setpoint by turning the charge/repos switch of the blackbody to repos: the blackbody temperature will slowly return to room temperature. Observe the image of the test pattern and note the temperature of the blackbody when the test pattern disappears: the MRTD is the difference between this temperature and the temperature of the test pattern.

↪ Repeat the measurement for a distance blackbody - camera of 1, 30 m, then 1, 50 m (in this last case, the temperature of the black body will be adjusted 2 °C above that of the test pattern before releasing the set point).

↪ Repeat the measurement with the $p = 1.55$ mm-period pattern.

Q13 Record the results on a graph. Choose the x-axis wisely ! It is recalled that the spatial frequency (in object space) is given by: $\nu = D/p$, where D is the black body - camera distance, and where p is the period of the target. If D is expressed in m and p in mm, ν is in cycles/mrad.

After characterizing the FLIR camera (measurements of NETD and MRTD), we propose to use it to discover two applications of infrared imaging: infrared thermography and non-destructive testing.

7 Absolute temperature measurement

Some applications of infrared thermography seek to detect local heating (e. g. thermal leak detection in buildings or predictive maintenance of electrical installations). In this case, the NETD (or MRTD) are well suited figures of merit for estimating the performance of an infrared camera. In other applications, the absolute temperature of an object (e. g. for monitoring damage to mechanical parts in the aeronautical industry, or for monitoring the proper functioning of a nuclear fusion reactor) can be measured precisely. We are now interested in this type of applications, which require more performance. In this section, we try to estimate the accuracy with which the FLIR camera can perform an absolute temperature measurement.

Set the temperature of the blackbody to 60 °C. Position the camera 60cm from the blackbody, and place a temperature measuring point in the middle of the blackbody (do not forget to indicate the emissivity and the reflected temperature !). Wait for the blackbody temperature to stabilize.

Q14 Knowing that the focal length of the lens is 24 mm and the pixel pitch is 17 μm , what is the field of view of one pixel? What surface does this field correspond to at the level of the blackbody?

↪ Insert the iris diaphragm between the blackbody and the camera (a few centimeters from the blackbody) and center it in relation to the temperature measurement point. Focus on the diaphragm. Perform a series of 4-5 temperature measurements for a diaphragm diameter ranging from 4 mm to full aperture.

Q15 Does the measured temperature vary according to the size of the diaphragm? Is this the expected result?

Q16 Compare any temperature variations observed with the previously measured NETD. Does NETD represent the accuracy with which it is hoped that an absolute temperature measurement can be achieved with this camera?

8 Non destructive testing (NDT)

In this section, we are interested in a particular application of infrared: non-destructive testing (NDT), which aims to highlight the presence of defects in the material by remote and non-contact measurement. Infrared imaging is thus used to detect defects in all kinds of materials, from composite materials used in aeronautics to agri-food products.

The principle of measurement is as follows: the surface of a sample is thermally excited and its surface temperature changes as a function of time. It is possible to show defects in the volume of the material.

Industrial NDT systems offer flash or halogen lighting, and the sensitivity of the sample to excitation can be observed in reflection (measurement on the front side) or transmission (measurement on the backside). In the framework of this lab, lighting is done with 400W halogen lamps and observation on the front side.

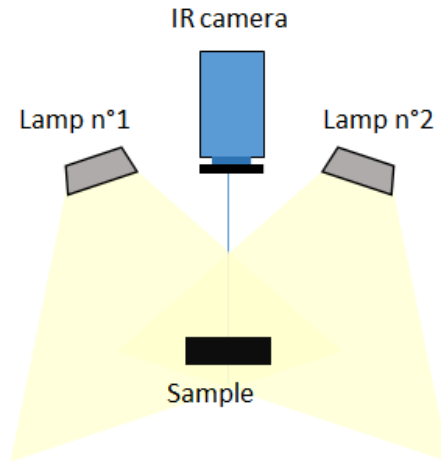

Figure 4.4: Experimental configuration used in this lab : excitation with halogen lamps, and front side observation.

↪ Position the two small frames in front of the camera (be careful with the thermal imprints you will leave when touching the objects!).

↪ Take a first infrared image of the two frames before lighting them. Turn on the halogen lamps for 10-15s and take a second image.

Q17 What are you observing? What do you deduce from this on the internal structure of the two objects?

↪ Now place the cardboard-covered sample (the cardboard side towards the camera) in front of the camera.

↪ Illuminate the sample for one minute and record the resulting infrared image.

Q18 Comment on it.

↪ Turn the sample over and illuminate the other side again for one minute.

Q19 What are you observing?

Annexe 1: Blackbody law

We recall for the record the law of the black body (Planck's law) seen during radiometry course:

$$\left[\frac{dL_e}{d\lambda} \right]_{\text{BB}}^T = \frac{2hc^2}{\lambda^5} \frac{1}{e^{\frac{hc}{\lambda k_B T}} - 1} \quad (4.5)$$

where $\left[\frac{dL_e}{d\lambda} \right]_{\text{BB}}^T$ is expressed in $\text{W} \cdot \text{m}^{-2} \cdot \text{sr}^{-1} \cdot \text{m}^{-1}$, T is the blackbody temperature in K, λ is the wavelength in m, $c = 3 \times 10^8$ m/s, $h = 6,63 \times 10^{-34}$ J·s (Planck's constant), and $k_B = 1,38 \times 10^{-23}$ J/K (Boltzmann's constant). As an example, we can compare this spectral luminance for various temperatures between 295 K and 315 K, *i.e.* 22°C and 42°C

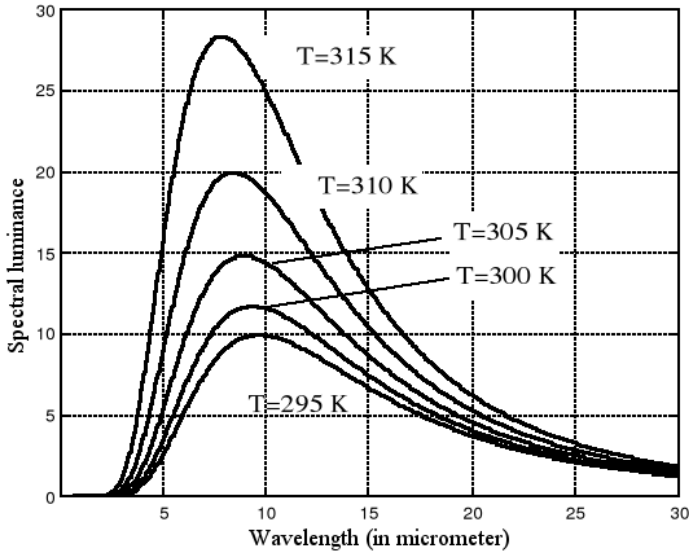

Figure 4.5: Spectral luminance of a black body (in $\text{W} \cdot \text{m}^{-2} \cdot \text{sr}^{-1} \cdot \mu\text{m}^{-1}$) as a function of wavelength, for various temperatures.

We see that the flux emitted from a black body increases with its temperature. The camera's bolometer is a thermal detector : it is sensitive to the incident power. Its sensitivity can be supposed constant on the IR band III (8-14 μm). The transmission of the lens can as well be considered as constant over

this band. With those hypothesis, the video signal obtained from the image of a black body of temperature T is :

$$v(T) = K \cdot \int_{8\mu\text{m}}^{14\mu\text{m}} \frac{dL}{d\lambda} (\lambda, T) d\lambda$$

The following curve shows the result of the computation of this integral for a temperature varying between 275 K and 325 K (approximately 0°C to 50°C)

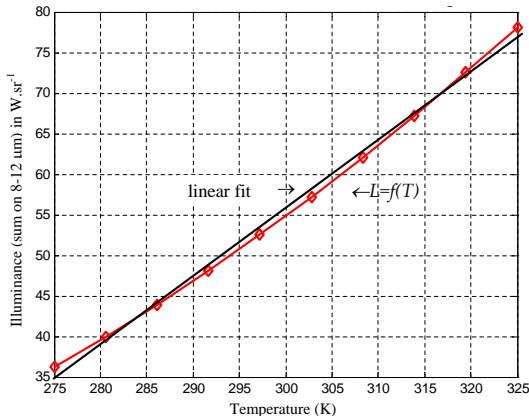

Figure 4.6: Total illuminance of the source, on the 8-12 μm band, as a function of its temperature.

We see that the hypothesis of a linear variation of the video signal with regard to the temperature is not realised. However, the error remains small on this limited temperature range of 20 to 40 °C.

Annexe 2 : MRTD measurement

We can show that the MRTD reads:

$$MRTD(\nu) = K \frac{NETD}{FTM_{\text{global}}(\nu)}, \tag{4.6}$$

where K is a constant and where the overall MTF of the camera is the product of the optical and detector transfer functions by a $S(\nu)$ function that accounts for the spatial response of the monitor and the eye (in all honesty, it is difficult

to define a transfer function for the eye because it is non-linear):

$$FTM_{\text{global}}(\nu) = FT_{\text{opt}}(\nu) \cdot FT_{\text{det}}(\nu) \cdot S(\nu) \quad (4.7)$$

In the rest of this annexe, the $S(\nu)$ function will be ignored.

It is recalled that the transfer function of an optics limited by diffraction (without aberrations or errors of realization, with a circular pupil) is given by:

$$FT_{\text{opt}}(\nu) = \frac{2}{\pi} \left[\arccos \left(\frac{\nu}{\nu_{c,\text{opt}}} \right) - \frac{\nu}{\nu_{c,\text{opt}}} \sqrt{1 - \left(\frac{\nu}{\nu_{c,\text{opt}}} \right)^2} \right], \quad (4.8)$$

where ν is the spatial frequency (in image space) and $\nu_{c,\text{opt}}$ is the cutoff frequency of the optics (also in image space), given by: $\nu_{c,\text{opt}} = \frac{1}{\lambda N}$.

In the hypothesis of a square pixel of a given pixel size, the detector MTF is given by:

$$FT_{\text{det}}(\nu) = \frac{\sin \left(\pi \frac{\nu}{\nu_{c,\text{det}}} \right)}{\pi \frac{\nu}{\nu_{c,\text{det}}}}, \quad (4.9)$$

where $\nu_{c,\text{det}}$ is the cutoff frequency of the detector (in image space): $\nu_{c,\text{det}} = \frac{1}{\text{pixel size}}$.

For the FLIR camera, the optics and detector modulation transfer functions are plotted in 4.7, along with the MRTD curve. This one grows with the spatial frequency, until reaching a vertical asymptote corresponding to the detector's cut-off frequency: this being lower than the optic's cut-off frequency, it is therefore the pixel size that limits the camera's resolution.

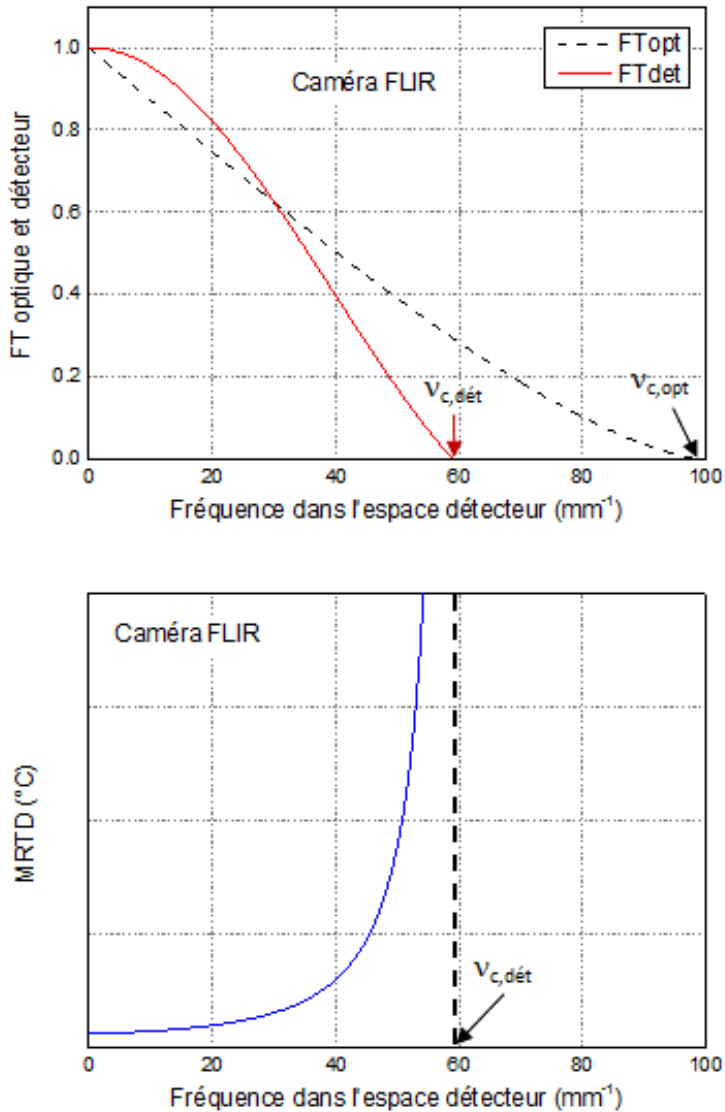

Figure 4.7: Upper panel : MTF of optics and detector, for the FLIR camera ; lower panel : MRTD of the FLIR camera. The vertical asymptote corresponds to the cutoff frequency of the detector.