

LEDs

Opto-Electronique / Semestre 5
Institut d'Optique

Julien VILLEMEJANE

LEDs et circuits d'émission

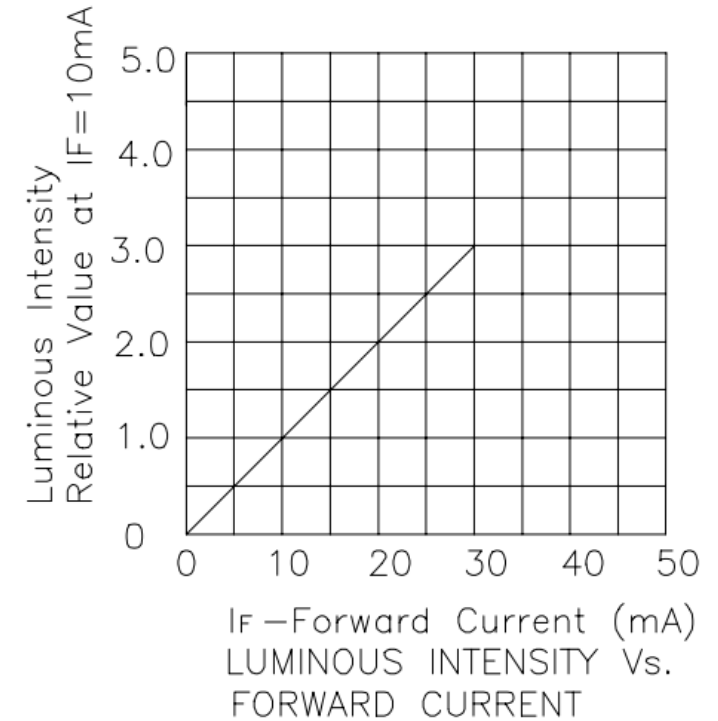
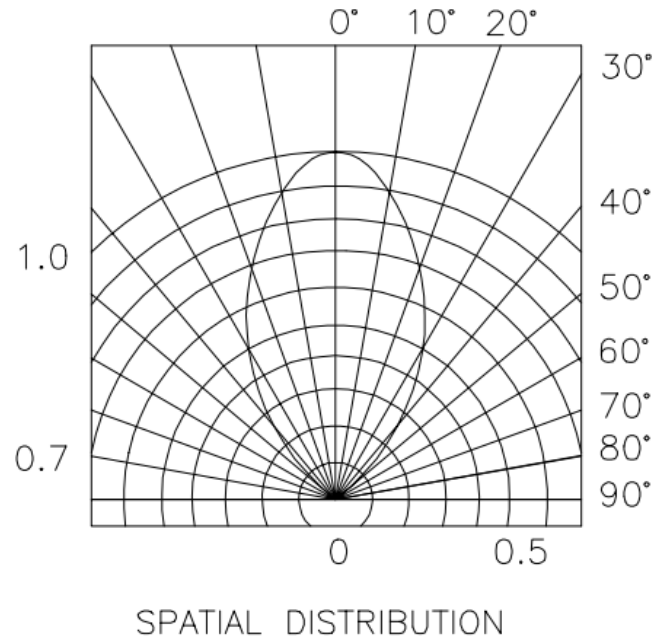
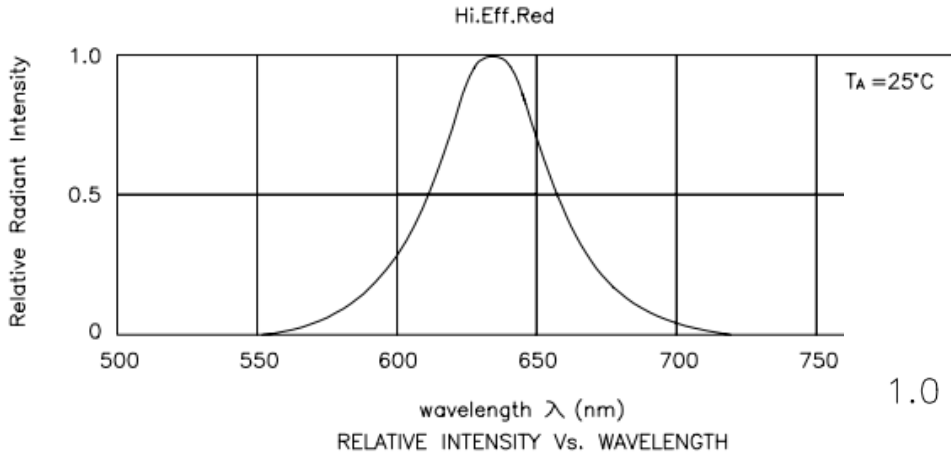

JõvseeÄeÄ nõtõõs

Caractéristiques électriques d'une LED



DIODE

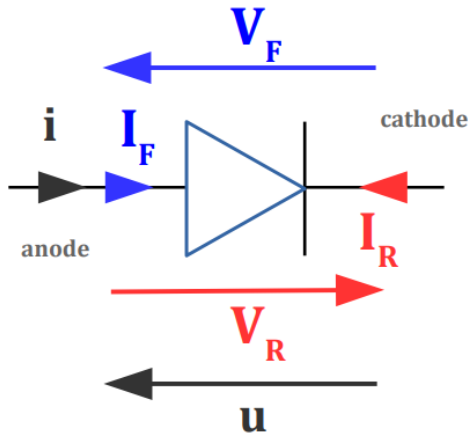

I_F : **courant direct**
 souvent $I_F < I_{FMAX}$
 V_F : **tension directe**
 aussi appelée seuil
 I_R : **courant inverse**
 V_R : **tension inverse**
 souvent $V_R < V_{RMAX}$

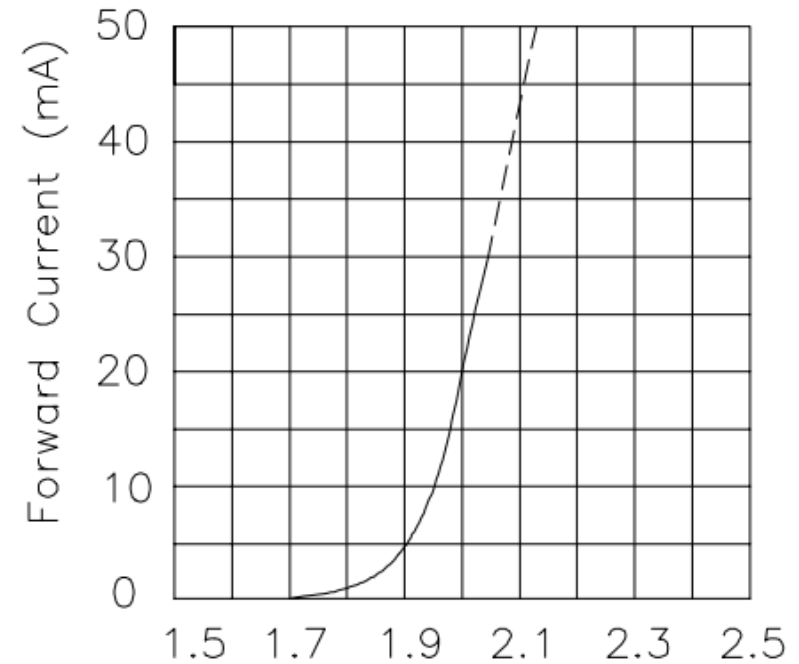
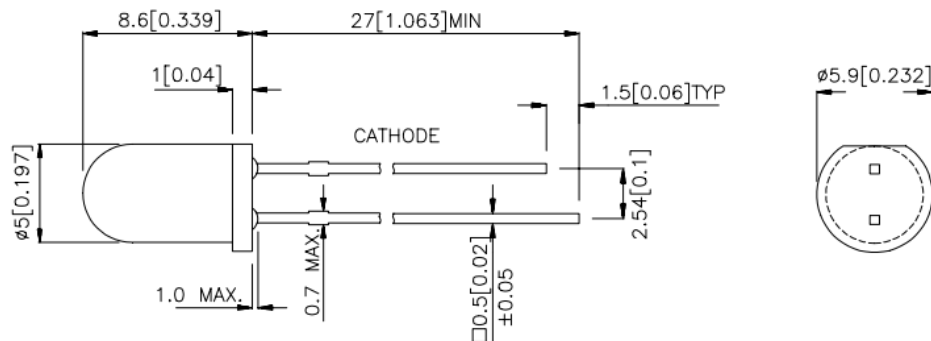

Forward Current (mA)
 FORWARD CURRENT Vs.
 FORWARD VOLTAGE

Kingbright

High Efficiency Red

L-531D

Caractéristiques électriques d'une LED



Idéalement : source de courant

Absolute Maximum Ratings at $T_A=25^\circ\text{C}$

Parameter	High Efficiency Red	Units
Power dissipation	105	mW
DC Forward Current	30	mA
Peak Forward Current [1]	160	mA
Reverse Voltage	5	V
Operating/Storage Temperature	-40°C To +85°C	
Lead Solder Temperature [2]	260°C For 5 Seconds	

Notes:

1. 1/10 Duty Cycle, 0.1ms Pulse Width.
2. 2mm below package base.

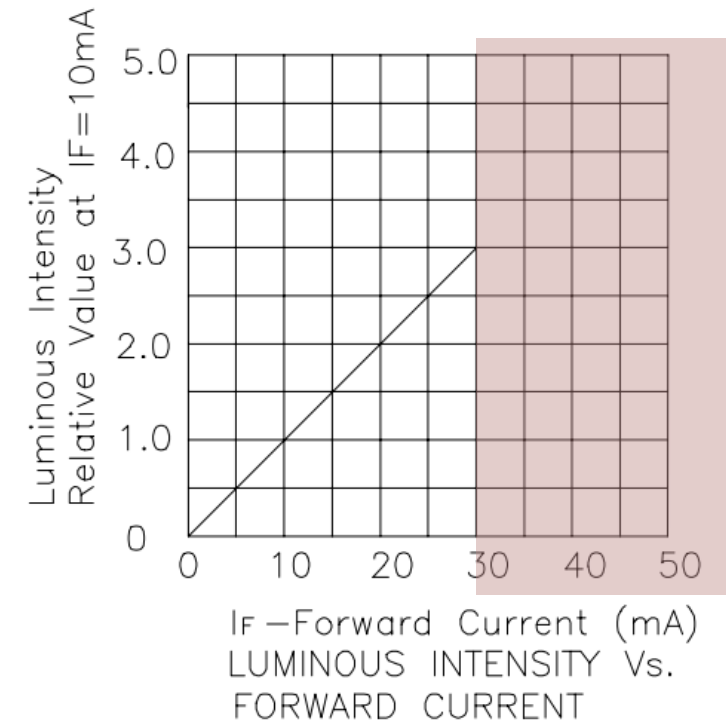

Kingbright

High Efficiency Red

L-53ID

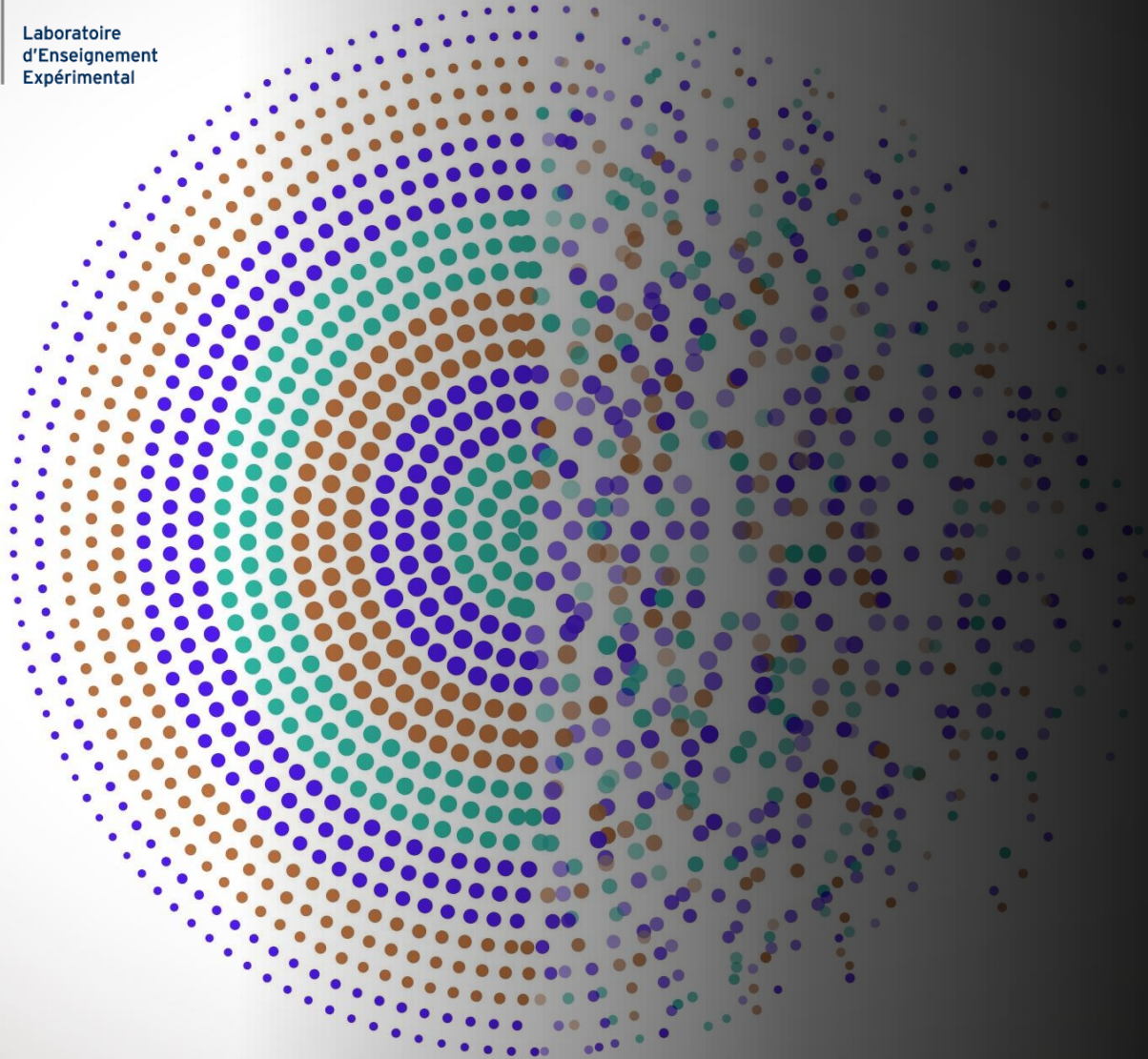

Photodétection

Opto-Electronique / Semestre 5
Institut d'Optique

Julien VILLEMEJANE

Photodiode, une diode mais...

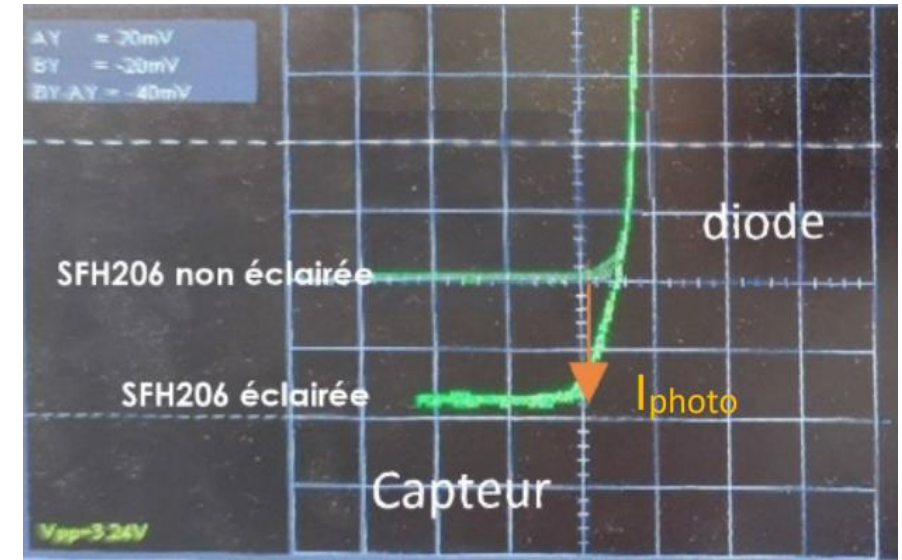
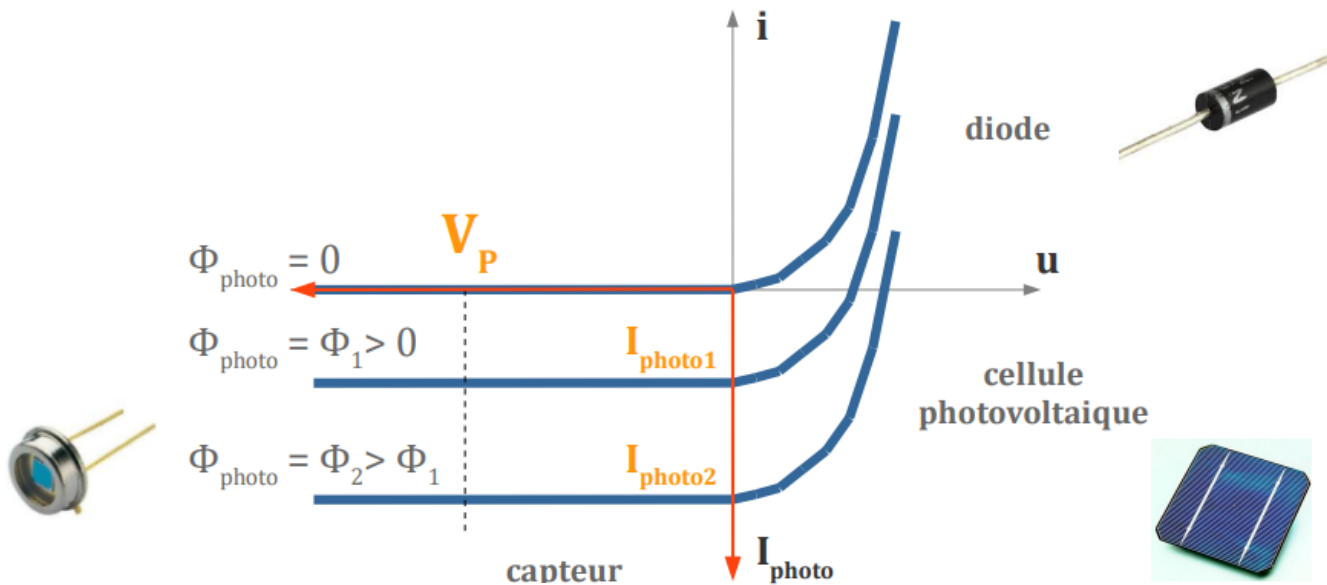
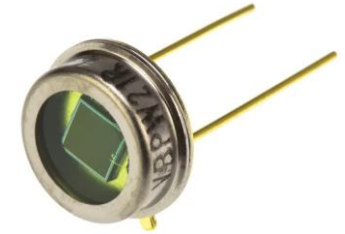

$$I_{\text{photo}} = S_{\lambda} \cdot \eta \cdot \Phi_{\text{photo}}$$

S_{λ} (A/W) → Sensibilité spectrale
 η → Rendement quantique
 Φ_{photo} (W) → Flux lumineux

<https://www.youtube.com/watch?v=KgKcbW77txY>

<https://www.youtube.com/watch?v=rNoHLOumplk>

Photodiode, une diode mais...

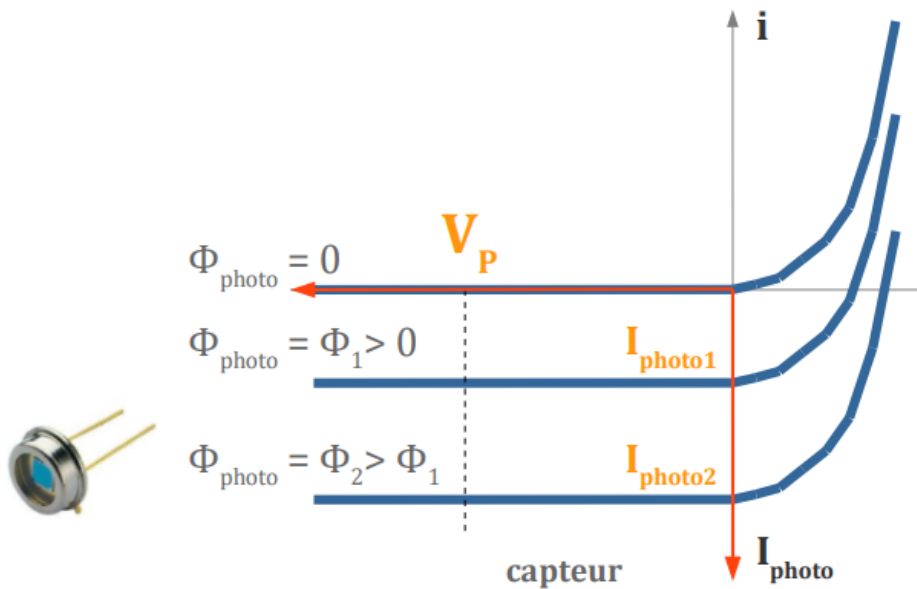
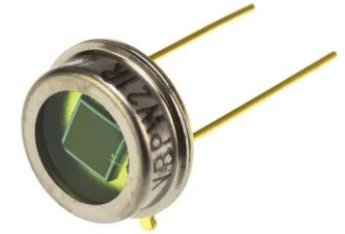

$$I_{\text{photo}} = S_{\lambda} \cdot \eta \cdot \Phi_{\text{photo}}$$

S_{λ} : Sensibilité spectrale
 η : Rendement quantique
 Φ_{photo} : Flux lumineux

SFH 206 K

Relative Spectral Sensitivity

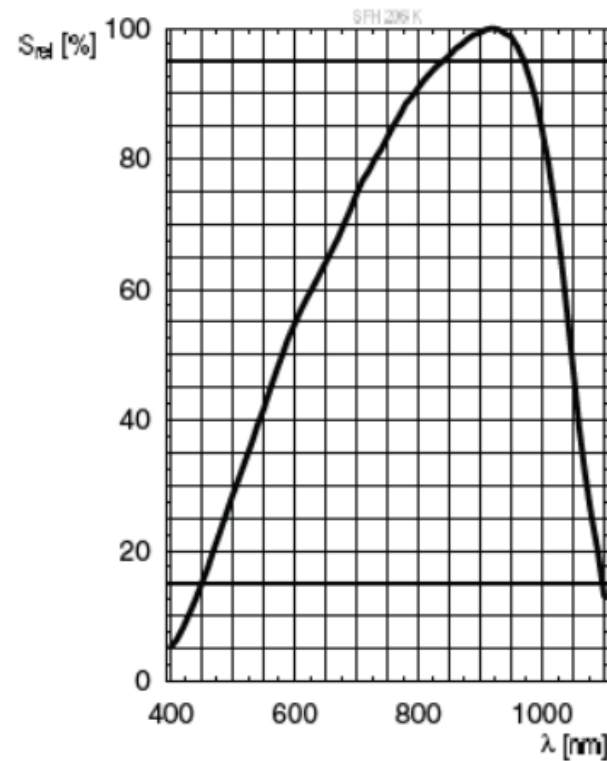

Photocurrent/Open-Circuit Voltage

$$I_P (V_R = 5 \text{ V}) / V_O = f(E_V)$$

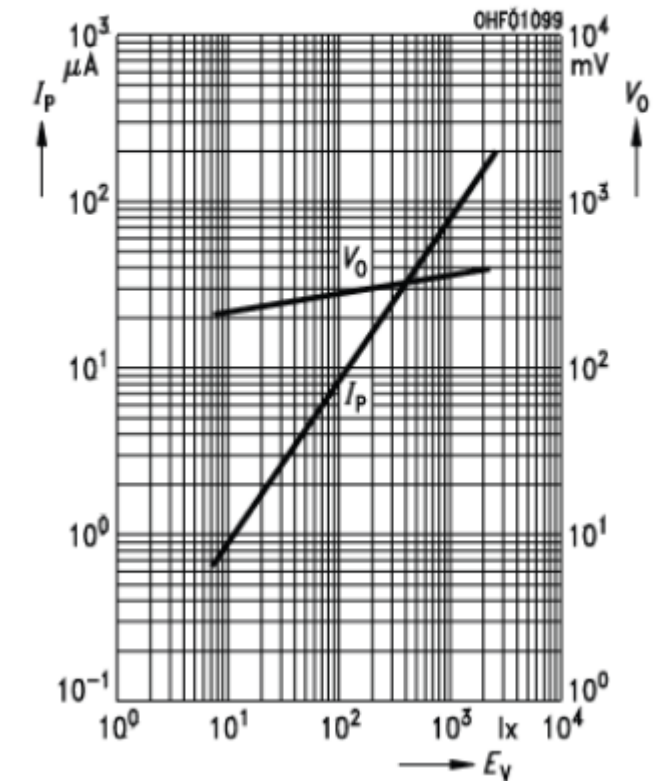

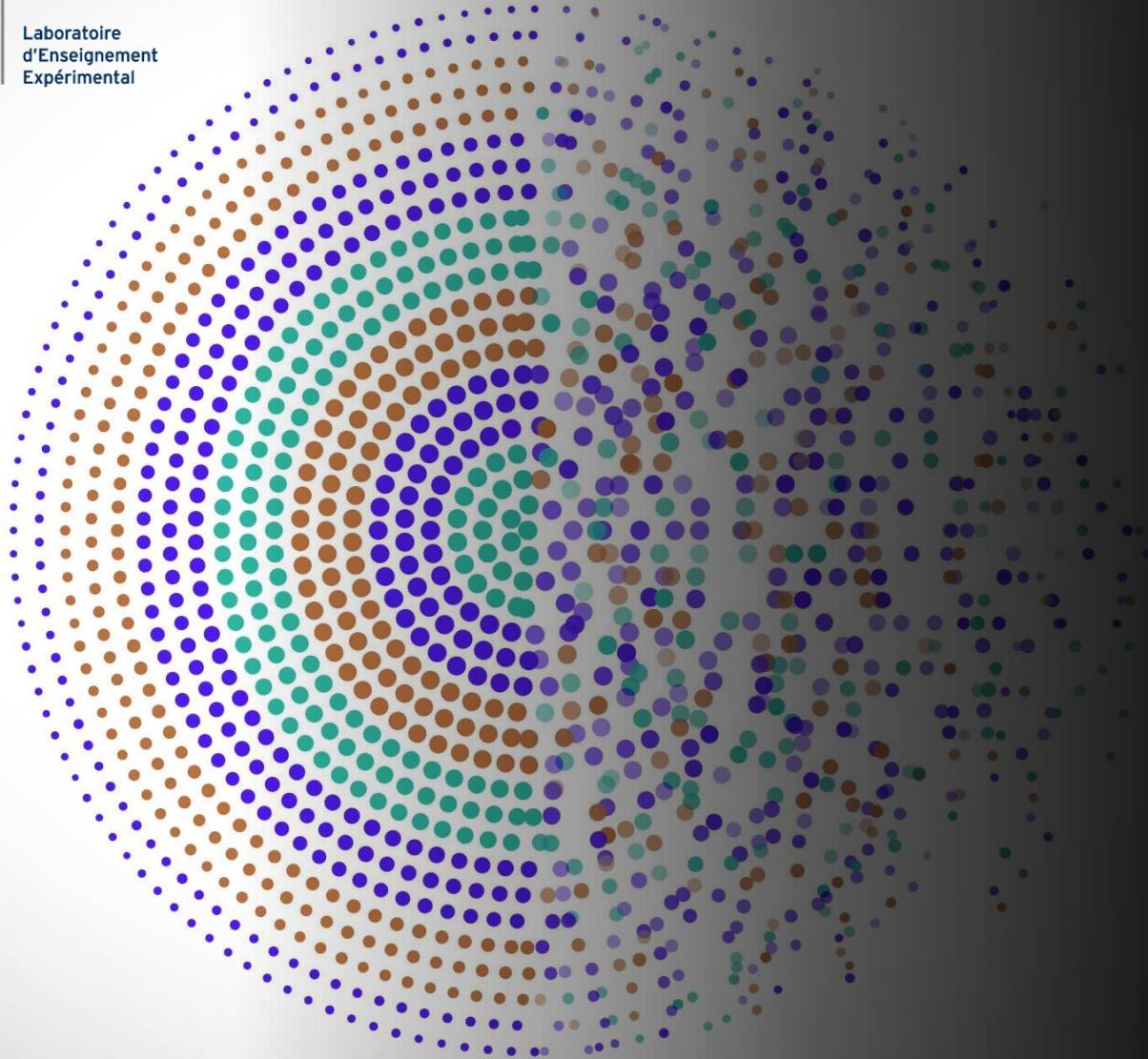

Photodétection

Montage simple

Opto-Electronique / Semestre 5
Institut d'Optique

Julien VILLEMEJANE

Montage de photodétection

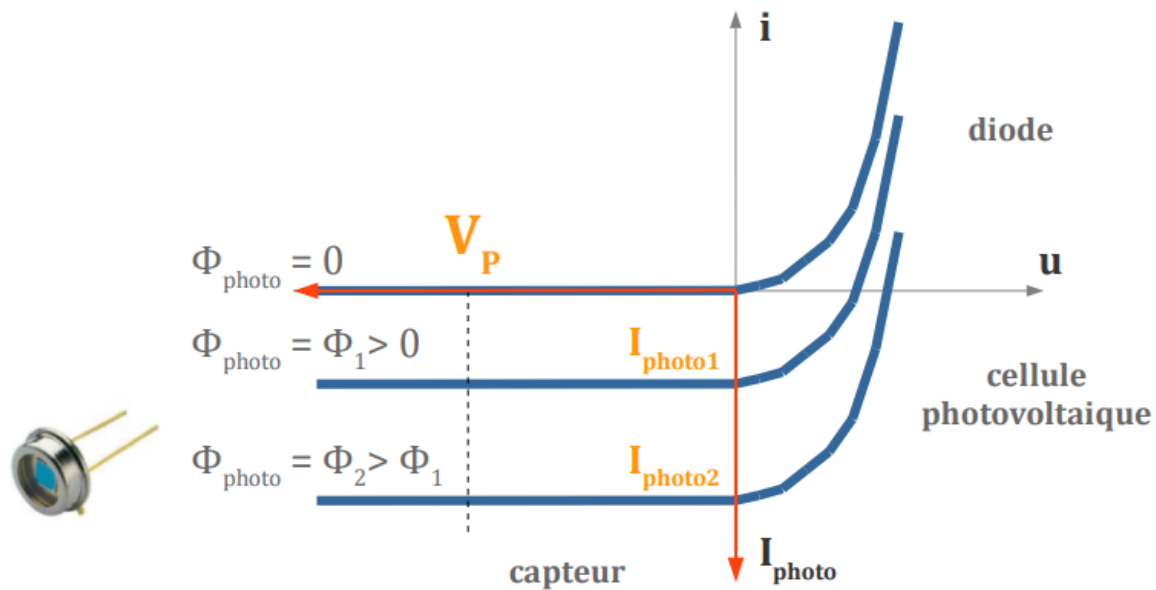
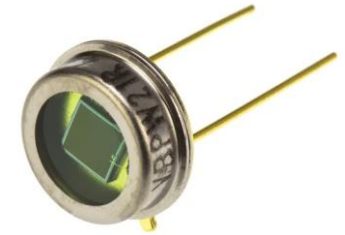

$$I_{photo} = S_{\lambda} \cdot \eta \cdot \Phi_{photo}$$

S_{λ} : Sensibilité spectrale
 η : Rendement quantique
 Φ_{photo} : Flux lumineux

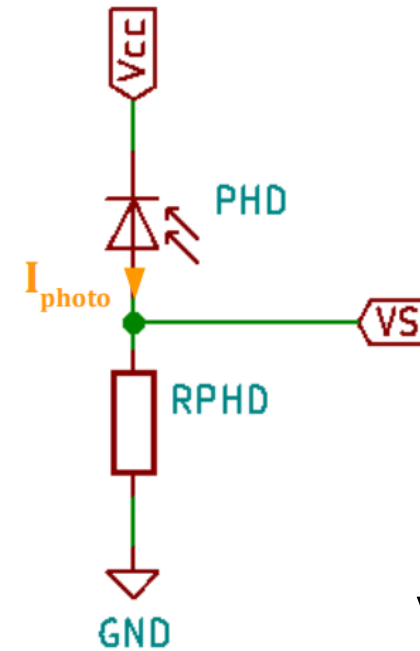

$$V_S = R_{PHD} \cdot I_{photo}$$

Montage de photodétection

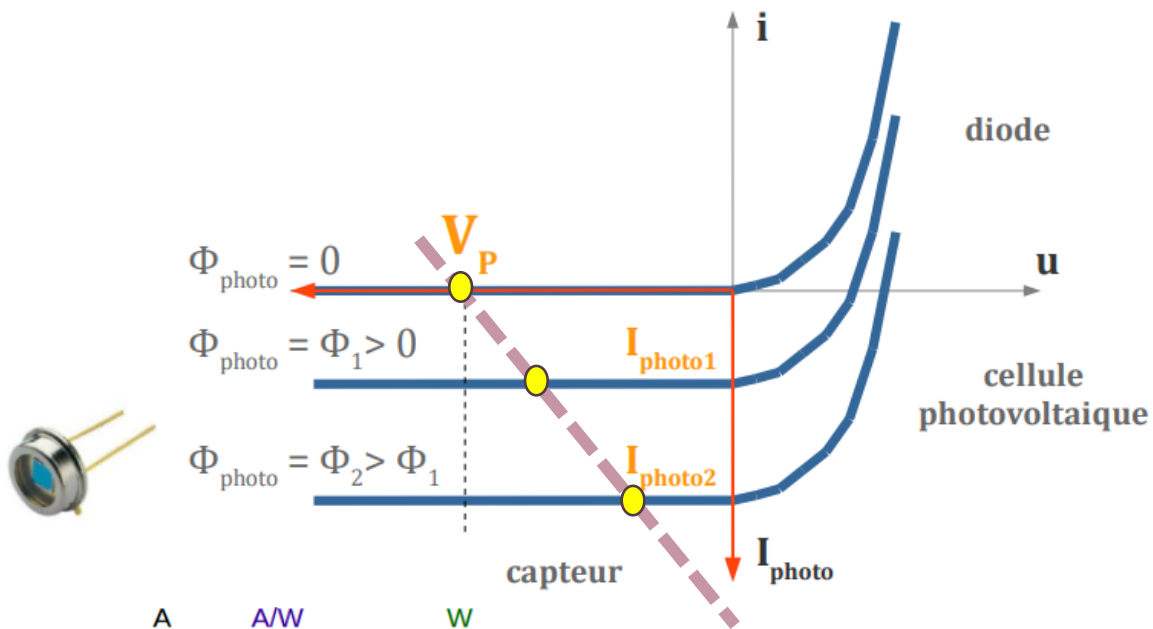
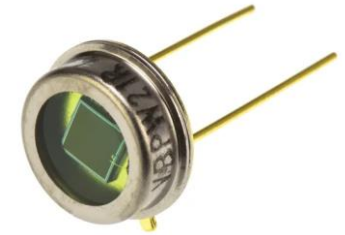

$$I_{\text{photo}} = S_{\lambda} \cdot \eta \cdot \Phi_{\text{photo}}$$

A A/W W

Sensibilité spectrale

Rendement quantique

Flux lumineux

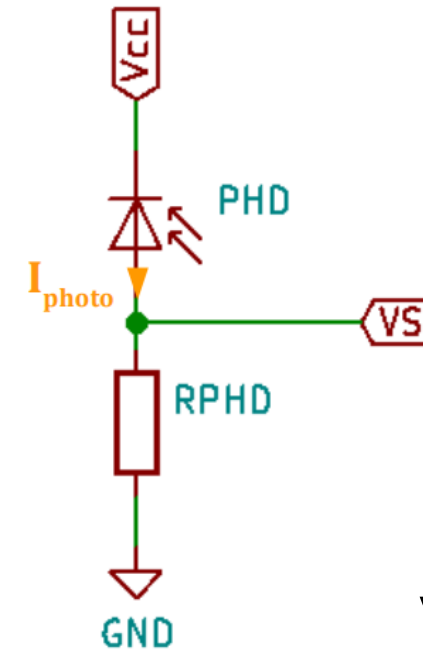

$$V_S = R_{\text{PHD}} \cdot I_{\text{photo}}$$

Tension de polarisation non constante

Etude expérimentale

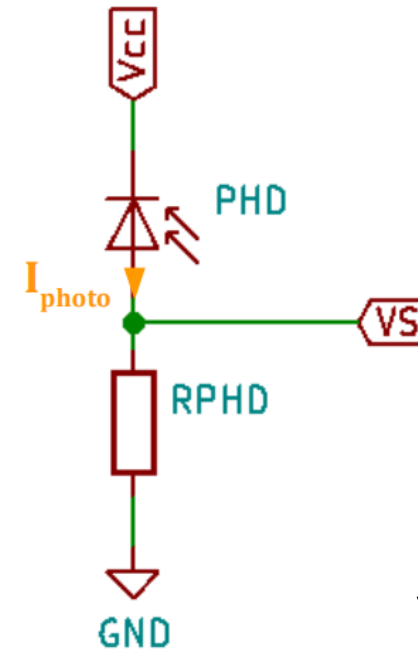
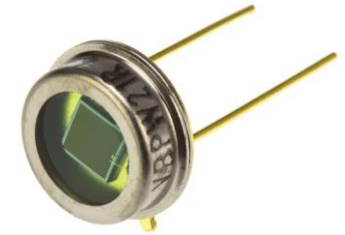

$$V_S = R_{PHD} \cdot I_{photo}$$

Modélisation

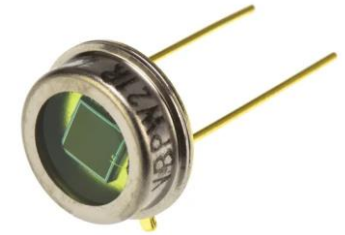

Bande passante réduite (à cause du système de mesure)

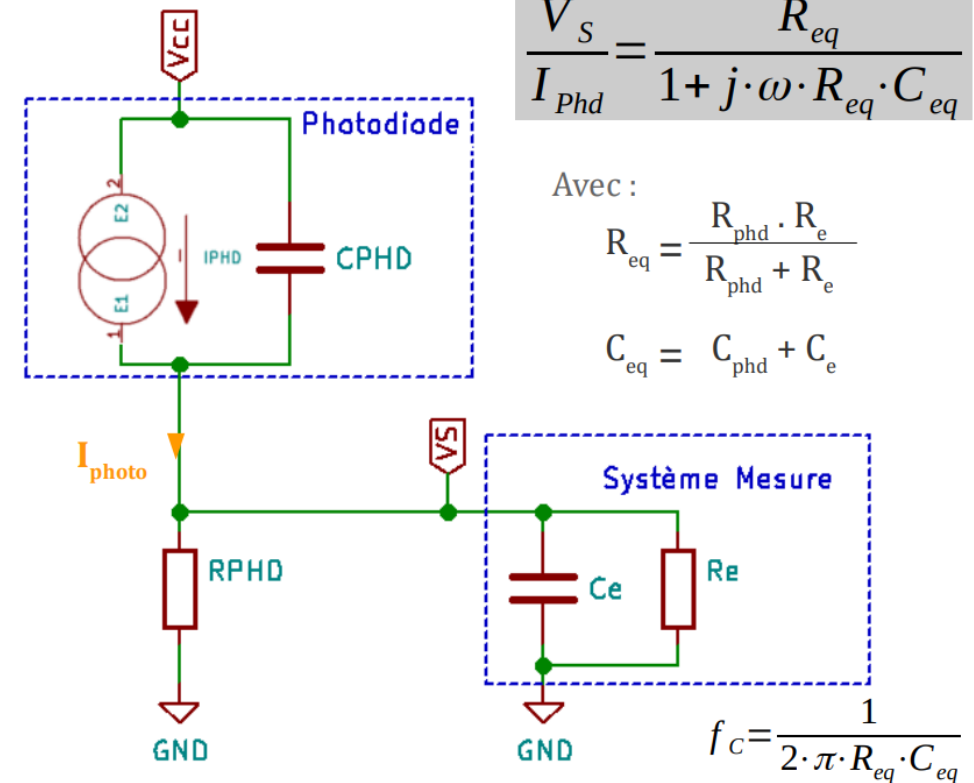

Modélisation

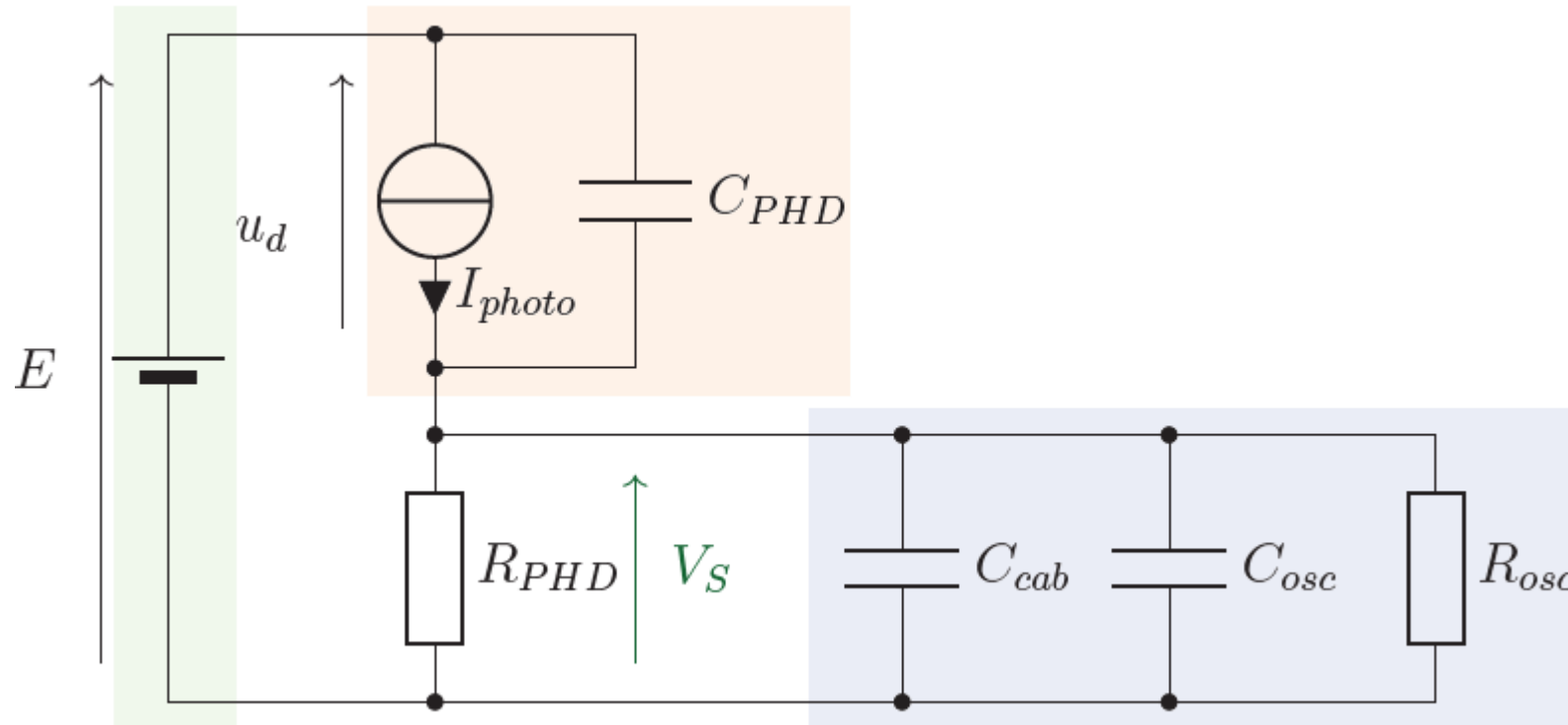
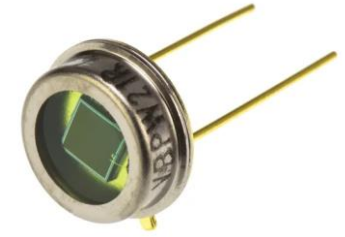

Bande passante réduite (à cause du système de mesure)

Amélioration / Montage Suiveur

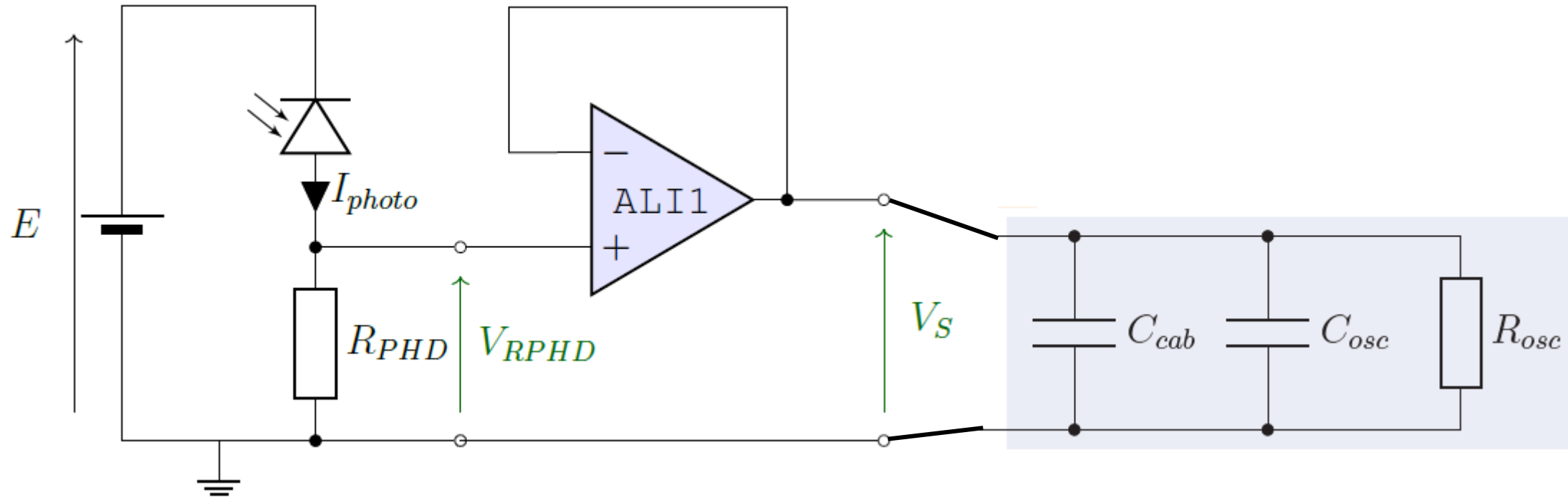
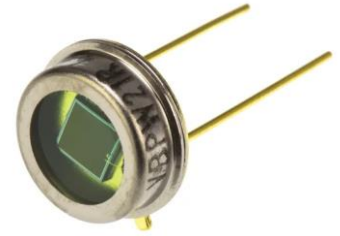

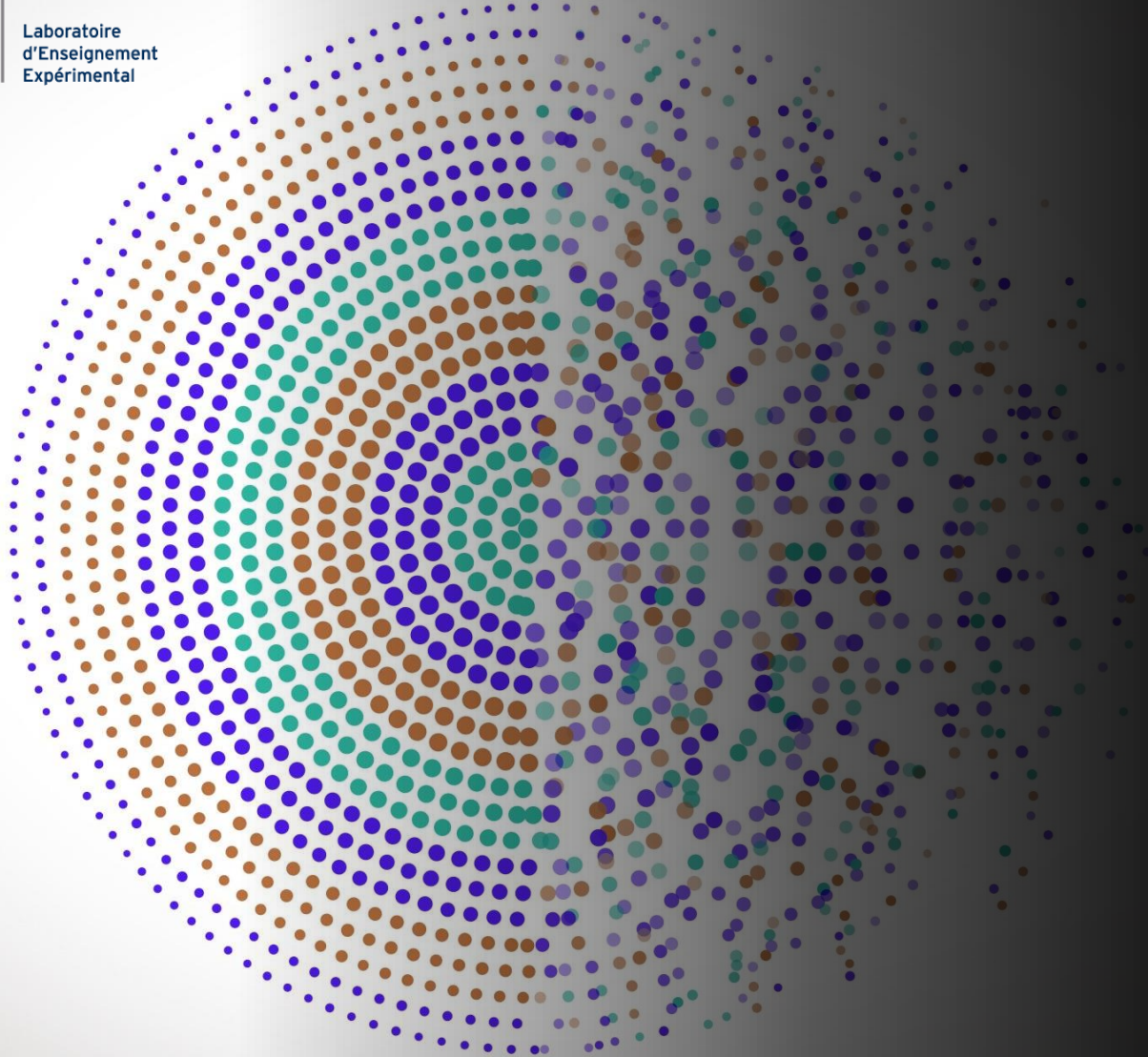

Photodétection

Montage transimpédance

Opto-Electronique / Semestre 5
Institut d'Optique

Julien VILLEMEJANE

Montage transimpédance

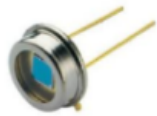
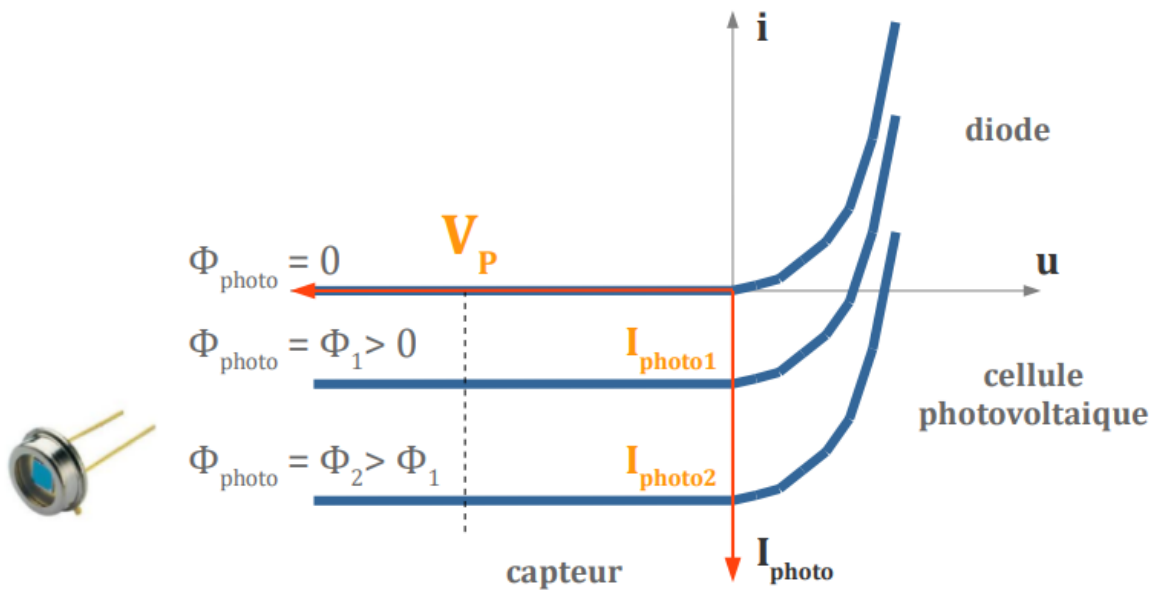
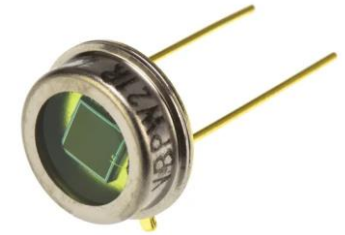

$$I_{photo} = S_{\lambda} \cdot \eta \cdot \Phi_{photo}$$

A A/W W

Sensibilité spectrale

Rendement quantique

Flux lumineux

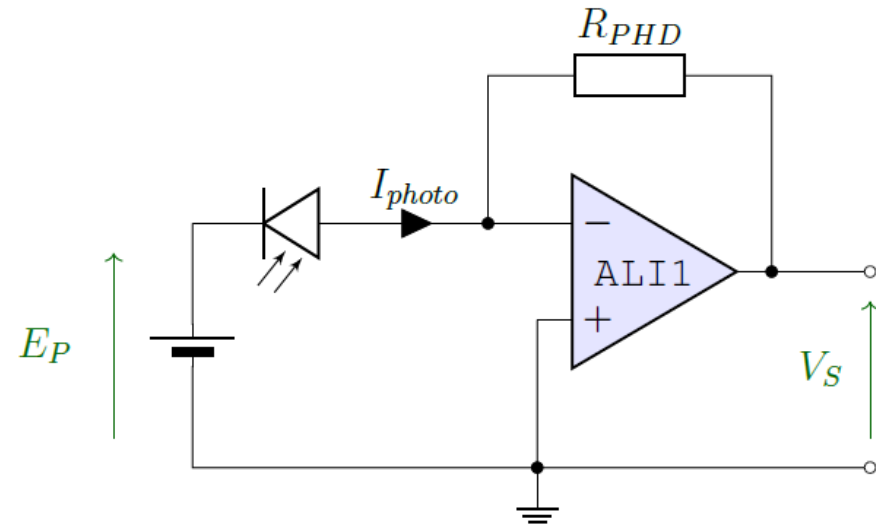

$$V_S = - R_{PHD} \cdot I_{photo}$$

Etude expérimentale

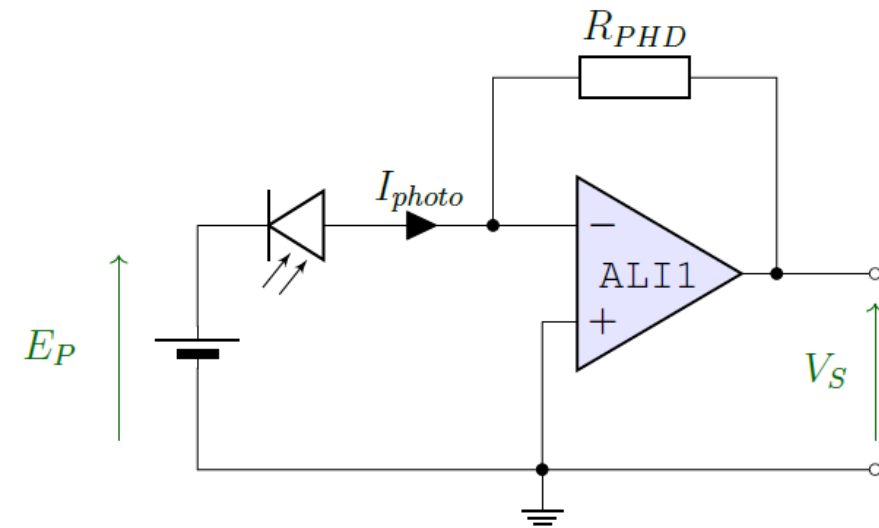
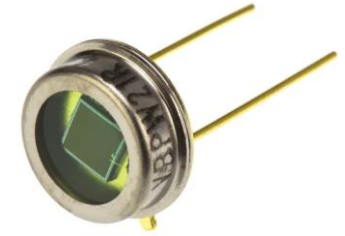

$$V_S = - R_{PHD} \cdot I_{photo}$$

Modélisation

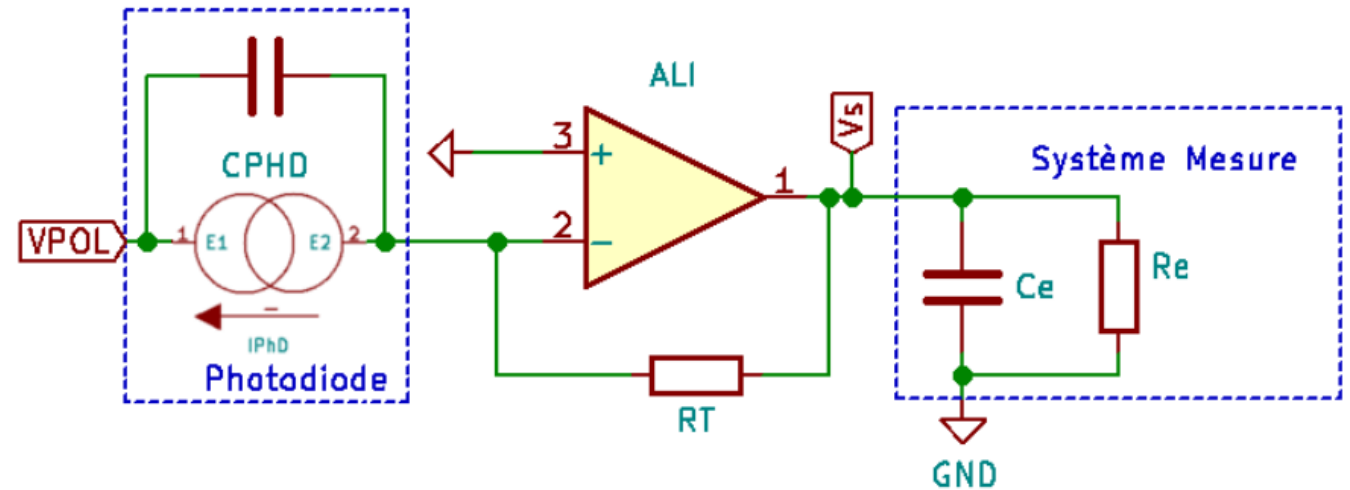
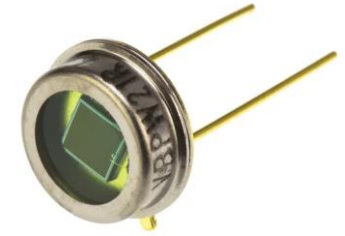

ALI / Passe-bas

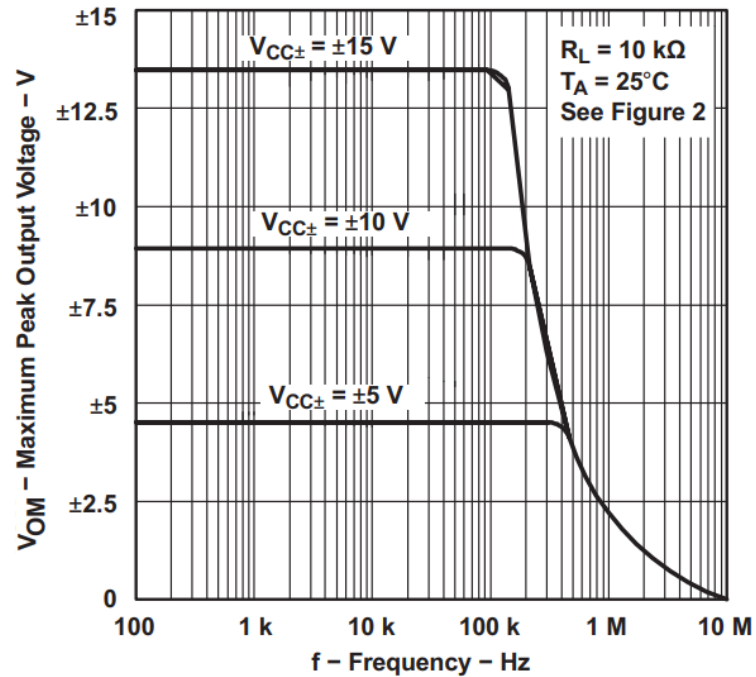

Figure 6-41. Maximum Peak Output Voltage vs Frequency

İ s̄öevøÄçö-Äçöëë-İ çššçöteÄööstçöt

INPUT CAPACITANCE				
Z _{ID}	Differential		100 2	MΩ pF
Z _{ICM}	Common-mode		6 1	TΩ pF
OPEN-LOOP GAIN				
A _{OL}	Open-loop voltage gain	V _S = 40 V, V _{CM} = V _S / 2, (V _{CC-}) + 0.3 V < V _O < (V _{CC+}) - 0.3 V	118	125
A _{OL}	Open-loop voltage gain	V _S = 40 V, V _{CM} = V _S / 2, R _L = 2 kΩ, (V _{CC-}) + 1.2 V < V _O < (V _{CC+}) - 1.2 V	115	120
FREQUENCY RESPONSE				
GBW	Gain-bandwidth product		5.25	MHz
SR	Slew rate	V _S = 40 V, G = +1, C _L = 20 pF	20	V/μs

ALI asservi / Modélisation

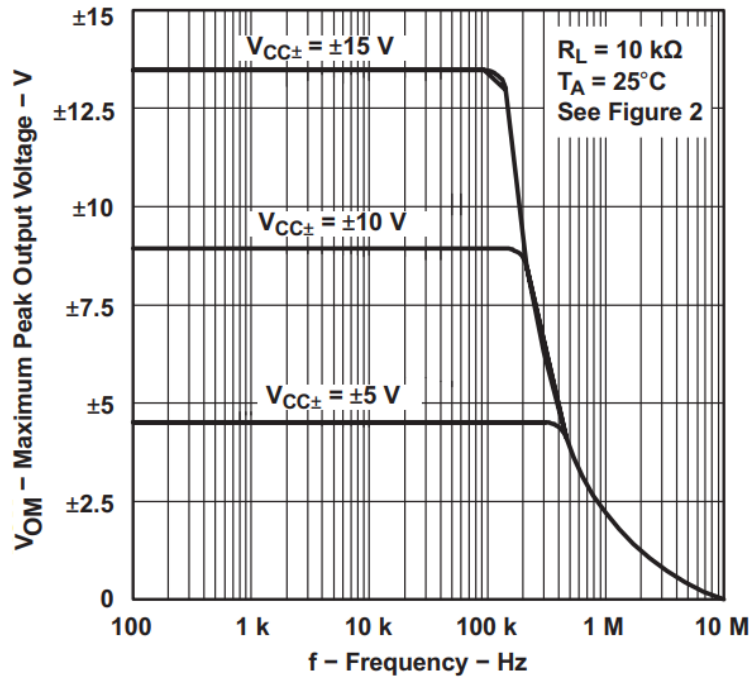
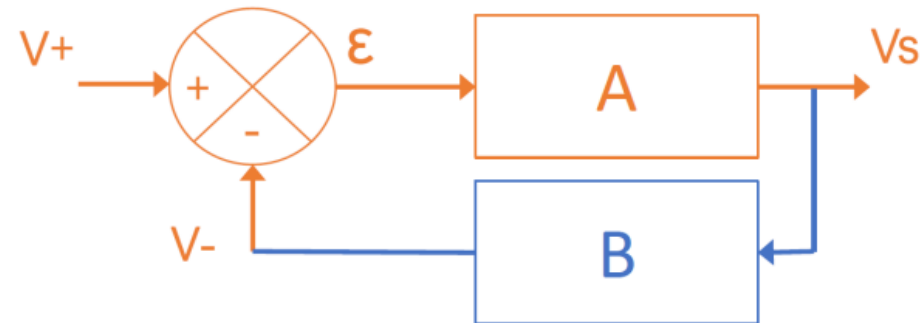

Figure 6-41. Maximum Peak Output Voltage vs Frequency

$$A(j\omega) = \frac{A_{MAX}}{1 + j \frac{\omega}{\omega_c}}$$



$$V_S = \frac{A(j\omega)}{1 + A(j\omega) \cdot B(j\omega)} V_E$$

Transimpédance / Modélisation

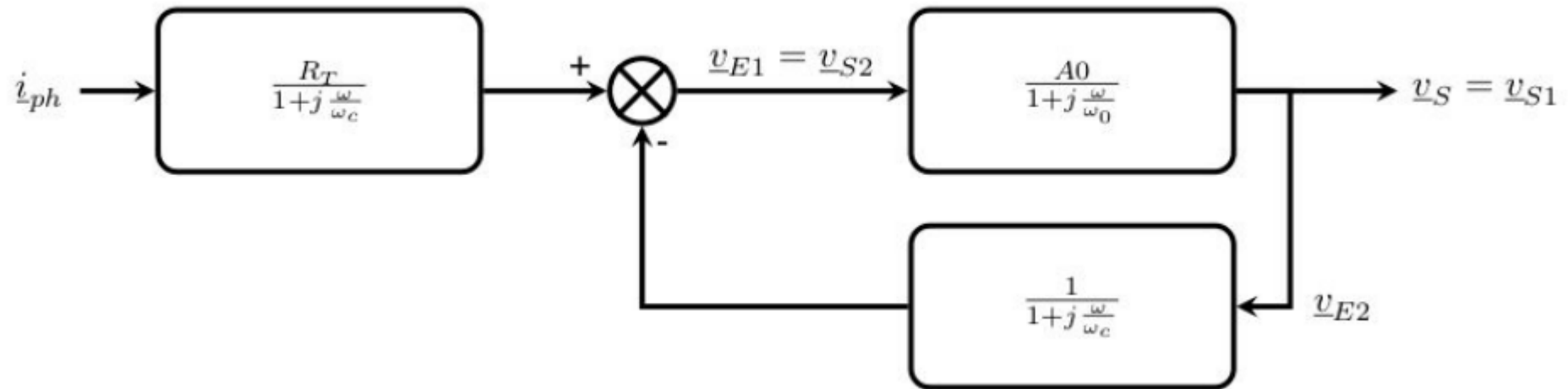

$$\frac{V_S}{I_{Phd}} = \frac{R_T \cdot A_0}{\left(1 + \frac{j \cdot \omega}{\omega_0}\right) \cdot \left(1 + \frac{j \cdot \omega}{\omega_c}\right) + A_0}$$

$$V_S = \frac{A(j\omega)}{1 + A(j\omega) \cdot B(j\omega)} V_E$$